

KDC-1022 KDC-122P

SERVICE MANUAL

CD mechanism extension cord : W05-0618-00

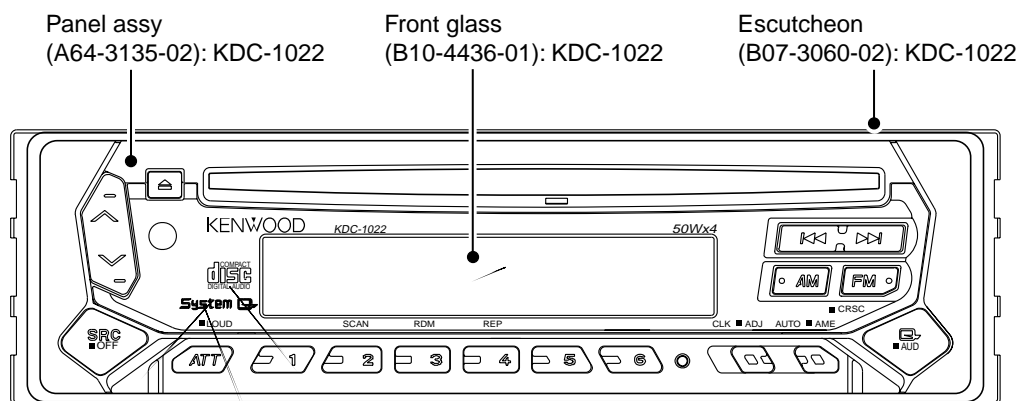
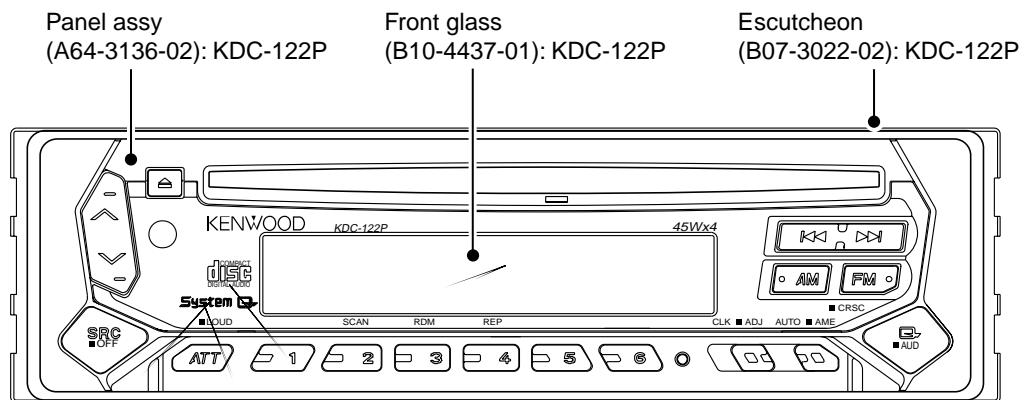

DC cord (E30-4784-05)

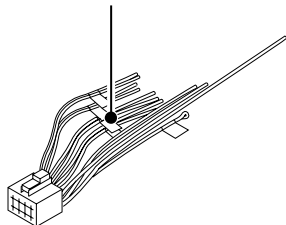

Mounting hardware assy (J21-9716-03)

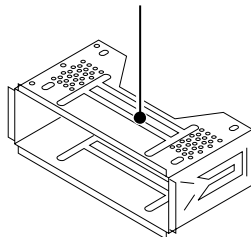

Lever (D10-4589-04)x2

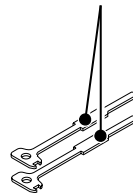

Screw set (N99-1719-05)

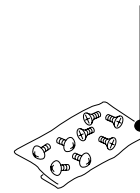

BLOCK DIAGRAM

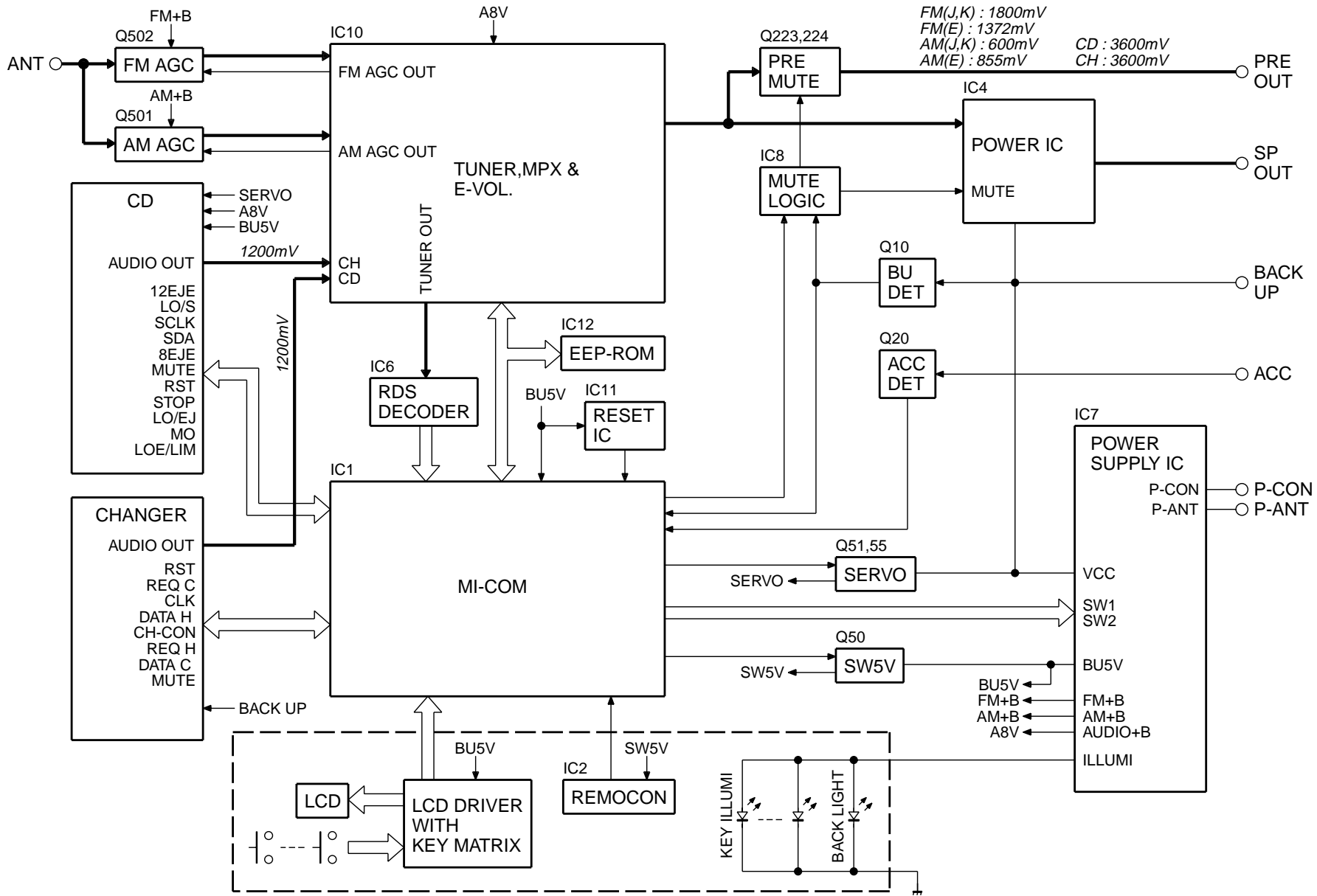

COMPONENTS DESCRIPTION

● SWITCH UNIT (X16-2370-12/13)

Ref. No.	Application/Functions	Operation/Condition/Compatibility
IC1	LCD driver & key matrix	
Q1	Key scan start	When Q1 base goes Lo, key scan start.

● ELECTRIC UNIT (X25-9600-13/14)

Ref. No.	Application/Functions	Operation/Condition/Compatibility
IC1	System control μ -com	System μ -com
IC4	Power amplifire	E-Vol output encoder power amplification for speaker.
IC7	Power supply (Multi AVR)	-
IC8	MUTE Logic	When a pin 1, 2, or 13 is "H", MUTE turns on. When a pin 3, 4, or 5 is "H", P-AMP mute turns on. Changer is RESET when a pin 9, 10, or 11 is "L".
IC10	Tuner & E-Vol.	FM/AM tuner & stereo decoder & E-Vol.
IC11	Power on reset	When B.U. 5V voltage is less than 3.5V, power reset.
IC12	E2P-ROM	Writing and read-out of adjustment data for a tuner.
Q10	B.U. detector	BU on (base "H") : Collector "H"
Q20	A.C.C detector	ACC on (base : "H") : Collector "L"
Q40	MUTE driver	Base "L" : Mute on (collector "L")
Q50	SW 5V	Base "L" : SW5V on
Q51	SERBO AVR control	Pin 2 "H" : Serbo on (pin 4 "H")
Q55	SERBO AVR	Base "H" : Serbo on
Q70	Surge detector	Base "H" : Surge detect
Q223,224	MUTE	Base "H" : Mute on
Q251		
Q501	AM RF amplifire	Base "H" : Gain UP
Q502	FM RF amplifire	Gate "H" : Gain UP

MICROCOMPUTER'S TERMINAL DESCRIPTION

● SYSTEM MICROCOMPUTER : UPD780058GC501 (X25 : IC1)

Pin No.	Name	I/O	Description	Processing Operation
1	TDF DET	I	Panel detection	H : Panel detached, L : Panel attached
2	8EJE SW	I		H : Eject is completed Except 8cm CD model : always output L
3	NC	O	Not used (out put L)	
4	Avss			
5	L-RST	O	LCD driver RESET	H : Panel detached, L : RESET Δ 3 normal H , Power off L When 7 seg model, output L
6	L-CE	O	LCD driver selection	H : Select (panel communication) When panel attached, output L

MICROCOMPUTER'S TERMINAL DESCRIPTION

Pin No.	Name	I/O	Description	Processing Operation
7	AVREF1			
8	NC		Not used (connected to 9pin)	
9	IC10-DATA	I/O	IC10, E2PROM data communication	Δ3 non communication : H
10	IC10-CLK	O	IC10, E2PROM clock communication	Δ3 non communication : H
11	L-DATAL	I	Data input from the LCD driver	Non communication : H, When panel detached : L Δ3 Pull down on X25 unit, Pull up on X16 unit
12	L-DATAS	O	Data output to the LCD driver	When panel detached, output L
13	L-CLK	O	Clock output to the LCD driver	When panel detached, output L
14	R-DATA	I	Data input from the RDS	Except RDS model : output L
15	R-QUAL	I	Quality input from the RDS	Except RDS model : output L
16	CH-DATAC	I	Data input from the changer (new 5L)	Except changer model : output L
17	CH-DATAH	O	Data output to the changer (new 5L)	When non communication, last data keeping Except changer model : output L
18	CH-CLK	I/O	Clock input/output with the changer (new 5L)	Check the old and new Except changer model : output L
19	CH-REQH	O	Request output to the changer (new 5L)	L : Requeset Except changer model : output L
20	NC	O	Not used (output L)	
21	AFS	O	Noise detection time constant switching terminal	H : Normal, L : FM/AM seek and AF search Δ3 (When tuner SRC auto zero, L)
22~24	NC	O	Not used (output L)	
25	CH-CONT	O	Changer control	H : Changer on, L : Changer off Except changer model : output L
26	TYPE REF	O	5V lines output for destination setting	H : During destination reading
27	SD	I	Tuner SD input	H : Station detected
28	NC	O	Not used (output L)	
29	TYPE2	I	Destination type selection terminal 2	Refer to destination type list.
30	TYPE1	I	Destination type selection terminal 1	Refer to destination type list.
31	TYPE0	I	Destination type selection terminal 0	Refer to destination type list.
32	TUNER-TYPE1	I	Destination available/genuine model rool off	H : genuine model 1, L : available model
33	Vss1			
34	TUNER-TYPE0	I	Destination available/genuine model noise cancel	H : genuine model 0, L : available model
35	MUTE	O	Mute (E.Vol, Preset) control	H : mute on, L : mute off Power off after that 15 second L
36	M-DATA	I/O	Data input/output with the CD mechanism	Δ3 non communication : H
37	M-CLK	O	Clock output to the CD mechanism	Δ3 non communication : H
38	ADJ	O	Tuner lines adjustment	When adjustment = H PS1-0, 1=L PS1-2, 2-0, 1=Hi-z IC10-DATA, CLK=Hi-z
39	P-MUTE	O	Power IC mute control	H : mute off, L : mute on Power off after that 15 second H
40	SVR	O	Power IC servo control	H : When momentary power down detected, L : Nomal
41	P-STBY	O	Power IC standby control	H : Power IC ON, L : Power IC OFF
42	SW5V	O	SW 5V control	H : SW5V OFF, L : SW5V ON Power off after that 10 second H
43	B.U-DET	I	Back up detection terminal	H : power down, L : B.U. on
44	ACC-DET	I	ACC detection terminal	H : ACC OFF, L : ACC ON

MICROCOMPUTER'S TERMINAL DESCRIPTION

Pin No.	Name	I/O	Description	Processing Operation																																				
45	PS1-0	O	Power supply IC SW1 control 0 Audio 8V, P-CON	<table border="1"> <thead> <tr> <th colspan="3">BA4911 SW1</th> <th colspan="3">Power supply IC output</th> </tr> <tr> <th>PS1-2</th> <th>PS1-1</th> <th>PS1-0</th> <th>A8V</th> <th>P-CON</th> <th>P-ANT</th> </tr> </thead> <tbody> <tr> <td>L</td> <td>L</td> <td>L</td> <td colspan="3">STANDBY</td> </tr> <tr> <td>L</td> <td>L (H)</td> <td>H (L)</td> <td>ON</td> <td>OFF</td> <td>OFF</td> </tr> <tr> <td>L</td> <td>H</td> <td>H</td> <td>ON</td> <td>ON</td> <td>OFF</td> </tr> <tr> <td>H</td> <td>H</td> <td>H</td> <td>ON</td> <td>ON</td> <td>ON</td> </tr> </tbody> </table>	BA4911 SW1			Power supply IC output			PS1-2	PS1-1	PS1-0	A8V	P-CON	P-ANT	L	L	L	STANDBY			L	L (H)	H (L)	ON	OFF	OFF	L	H	H	ON	ON	OFF	H	H	H	ON	ON	ON
BA4911 SW1			Power supply IC output																																					
PS1-2	PS1-1	PS1-0	A8V	P-CON	P-ANT																																			
L	L	L	STANDBY																																					
L	L (H)	H (L)	ON	OFF	OFF																																			
L	H	H	ON	ON	OFF																																			
H	H	H	ON	ON	ON																																			
46	PS1-1	O	Power supply IC SW1 control 1 Audio 8V, P-CON																																					
47	PS1-2	O	Power supply IC SW1 control 2 P-ANT																																					
48	PS2-0	O	Power supply IC SW2 control 0 ILL, FM, AM	<table border="1"> <thead> <tr> <th colspan="2">BA4911 SW2</th> <th colspan="3">Power supply IC output</th> </tr> <tr> <th>PS2-1</th> <th>PS2-0</th> <th>ILLUMI</th> <th>FM</th> <th>AM</th> </tr> </thead> <tbody> <tr> <td>L</td> <td>L</td> <td colspan="3">STANDBY</td> </tr> <tr> <td>L (H)</td> <td>H (L)</td> <td>ON</td> <td>ON</td> <td>OFF</td> </tr> <tr> <td>H</td> <td>H</td> <td>ON</td> <td>OFF</td> <td>ON</td> </tr> </tbody> </table>	BA4911 SW2		Power supply IC output			PS2-1	PS2-0	ILLUMI	FM	AM	L	L	STANDBY			L (H)	H (L)	ON	ON	OFF	H	H	ON	OFF	ON											
BA4911 SW2		Power supply IC output																																						
PS2-1	PS2-0	ILLUMI	FM	AM																																				
L	L	STANDBY																																						
L (H)	H (L)	ON	ON	OFF																																				
H	H	ON	OFF	ON																																				
49	PS2-1	O	Power supply IC SW2 control 1 ILL, FM, AM																																					
50	BEEP		BEEP																																					
51	DSI	O	DSI control	H : Light on, L : Light off, When panel attached, output L When panel detached, flashing at the panel (H/L) FIX model is output L																																				
52,53	NC	O	Not used (out put L)																																					
54	LOE/LIM SW	I	CD mechanism down & limit detection	H : Chucking detection, L : Normal																																				
55	MO SW	O	CD mechanism loading motor control output	H : Loading, Eject, Break, L : Play																																				
56	LO/EJ	I/O	CD mechanism loading/Eject switching terminal	H : Eject, L : Loading																																				
57	M-STOP	O	Stop output to the CD mechanism	H : Play, L : Stop																																				
58	M-RST	O	Reset output to the CD mechanism	H : Normal, L : CD mechanism reset																																				
59	M-MUTE	I	Mute input from the CD mechanism	H : mute off, L : mute on																																				
60	RESET		Reset input from the System microcomputer																																					
61	REMO	I	Remote control input																																					
62	R-CLK	I	RDS clock input	Except RDS model : output L																																				
63	CH-REQC	I	Request input from the changer (new 5L)	H : Changer detection, L : Request Except Changer model : output L																																				
64	LOS SW	I	CD mechanism loading's switch detected	H : No disc, L : DISK IN (Loading Start)																																				
65	KEY-REQ	I	Key input detected (11pin L connected to the DATA L)	H : Key no input, L : Key input (edge key data reading start)																																				
66	12EJE SW	I	12cm disc detected	L : 12cm disc																																				
67	Vss0																																							
68	VDD1																																							
69	X2		$\Delta 3$ MAIN X'tal oscillating circuit	$\Delta 3$ 4.19MHz X'tal connection																																				
70	X1		$\Delta 3$ MAIN X'tal oscillating circuit	$\Delta 3$ 4.19MHz X'tal connection																																				
71	IC		TEST																																					
72	XT2		Not used	OPEN																																				
73	XT1																																							
74	VDD0		VDD	Connected to VDD																																				
75	AVREF0		A/D converter reference voltage control output, connection to the 80pin AVCONT																																					
76	S-METER	I	S-meter input																																					
77	NOISE	I	FM noise detection input	$\Delta 3$																																				
78	PHONE	I	2way mute	2.5V or greater : NAVI MUTE, 1.0V or less : TEL MUTE Except phone mute model : output L																																				
79	NC	O	Not used (output L)																																					
80	AVCONT	O	A/D converter standard voltage control output	H : During A/D converter active, Same timing with PON																																				

KDC-1022/122P

MICROCOMPUTER'S TERMINAL DESCRIPTION

● System μ -com Destination type list

	TYPE2	TYPE1	TYPE0	MODEL NAME
UPD780058GC499	L	L	L	KDC-2024SA/SYA, 2024SG/SYG
	L	L	H	KDC-2022, 2022V, 202MR
	L	H	L	RY-391CD, RX-491CD
	L	H	H	KDC-4023, 2023, 3023
UPD780058GC501	L	L	H	KDC-122, 122S, 1022, 122P
	L	H	H	KDC-1023, 1023S
	H	L	H	KDC-222, 222S
UPD780058GC502	L	L	L	KDC-3024G/YG, 307G/YG
	L	H	H	KDC-3023R
	H	L	L	KDC-3024A/YA, 307A/YA
	H	L	H	KDC-4024Y/V/YV
UPD780058GC503	L	L	L	KDC-2094YA/YG
H :	R135	R137	R139	
L :	R136	R138	R140	

● MECHANISM MICROCOMPUTER : MN6627771KP (X32 : IC2)

Pin No.	Name	I/O	Description	Processing Operation
1	TVD	O	Traverse driver output (PWM output)	
2	SPL	O	Spindle motor drive output (PWM output)	
3	PC	O	Spindle motor ON output	L : ON, H : OFF (default)
4	PWM	O	multi-purpose PWM output	It's possible to setup the TOSF2
5	TBAL	O	Tracking balance adjust output (PWM output)	
6	FBAL	O	Focus balance adjust output (PWM output)	
7	NRFDET	I	RF detection signal input	L : detected
8	OFT	I	Off-track signal input	H : detected
9	BDO	I	Drop out signal input	H : detected
10	LDON	O	Laser on signal output	H : ON, When command FO on, LDON is H
11	DSL B	O	DSL balance output	
12	DVDD1	-	Power supply for digital circuit	
13	DVSS1	-	Ground lines for digital circuit	
14	AVSS2	-	Ground lines for analog circuit	For DSL, PLL and AD
15	DSL F	I/O	Loop filter terminal for DSL	The bias of ARF output terminal in one
16	ARF	I	RF signal input	
17	RFSW	I	When DSL circuit, constant switch terminal	
18	PLL F	I/O	Loop filter terminal for PLL	
19	PLL F2	I/O	Loop filter characteristic switching terminal for PLL	
20	IREF	I	Standard voltage input terminal	
21	RFENV	I	RF envelope signal input	Analog input
22	TRCRS	I	Track cross signal input	Analog input
23	TE	I	Tracking error signal input	Analog input
24	FE	I	Focusing error signal input	Analog input
25	AVDD2	-	Power supply for analog circuit	For DSL, PLL and AD
26	AVSS1	-	Ground lines for analog circuit	For audio output (Lch and Rch in one)
27	OUTR	O	Rch audio output	
28	AVDD1	-	Power supply for analog circuit	For audio output (Lch and Rch in one)
29	OUTL	O	Lch audio output	
30	DVSS3	-	Ground lines for digital circuit	
31	CSEL	I	Oscillation frequency specification terminal	H : 33.8488MHz, L : 16.9344MHz

MICROCOMPUTER'S TERMINAL DESCRIPTION

Pin No.	Name	I/O	Description	Processing Operation
32	NC	O	Not used	
33	ASEL	I	Audio output polarity switching terminal	L : Reverse, H : Non reverse
34	MSEL0	I	Destination type selection port (set 2bit)	Order "MSEL 0" and "MSEL 1" Set up
35	MSEL1	I	Destination type selection port (set 2bit)	Order "MSEL 0" and "MSEL 1" Set up
36	ICRST	O	Reset control terminal for external DAC	
37	BCLK	O	Bit clock output for serial data	
38	LRCK	O	L/R identification signal output	
39	SRDATA	O	Serial data output	
40	VREFP	I	A/D converter standard power supply input	
41	HOT	I	Temperature protection detection terminal (AD input)	Over C5(h) : on
42	8EJE_SW	I	8cm disc eject stop detection terminal	H : Stop
43	12EJE/SDET_SW	I	Judge the 8cm or 12cm disc	12cm disc stop detection terminal
44	LOE/LIM_SW	I	Pick-up inside detected	Loading end detection terminal
45	PCK	O	PLL extracted clock output, etc	
46	EFM	O	EFM signal output, etc	
47	SENSE	O	Optics servo status signal output, etc	
48	CLVS	O	Spindle servo phase synchronous signal output, etc	L : Normal operation, H : Luff servo
49	DEMPH	O	Dephase detection signal output, etc	H : on
50	DVDD2	-	Power supply for digital circuit	
51	X1	I	Main clock input terminal	
52	X2	O	Main clock output terminal	
53	DVSS2	-	Ground lines for digital circuit	
54	XSUB1	I	When external DAC, external clock input terminal	
55	XSUB2	O		
56	TEST1	I	Test port 1	Normal operation is H fixed
57	TEST2	I	Test port 2	Normal operation is H fixed
58	NC	O	Not used	
59	VER/HOR	O	Put length or breadth switching motor terminal	H : Put length, L : Put breadth
60	DRV_MUTE	O	Driver mute control terminal	L : MUTE ON, H : MUTE OFF
61	/MUTE_L	O	Audio Lch MUTE output	L : MUTE
62	/MUTE_R	O	Audio Rch MUTE output	L : MUTE
63	/RST	I	LSI reset input terminal	H : Normal, L : Reset
64	OCD_CLK	I	When OCD connected, clock input	
65	/MSTOP	I	Standby detection terminal	H : Normal, L : Mecha stop
66	DATA	I/O	I2C bus data line (communication line with system computer)	At that time serial writer connected
67	SBIO	I	When connected to serial writer, data input terminal	
68	/CLK	I/O	I2C bus clock line (communication line with system computer)	At that time serial writer connected
69	TX	O	Digital audio interface signal output	
70	EQCNT	O	RF EQ switching terminal	L : x2 times, H : x1 times
71	XSEL	I	During the external DAC connection	MCLK external input (H : input)
72	MCNT	I	CD mecha Loading/Eject control ON/OFF	L : OFF (HOST control), H : mechanism control
73	P-ON	O	Audio and servo origin power control terminal	L : power on, H : power off
74	MOTOR	O	Loading/Eject control switching terminal	At that time LO/EJ is "H"
75	LO/EJ	O	Loading/Eject control terminal or output L	When 72pin (P82) is "L", output "L"
76	CD-RW	O	CD-RW control terminal	H : CD-RW, L : normal
77	LDCNT	O	LD control terminal	Operation is same LDON as timing
78	DVDD3	-	Power supply for digital circuit	
79	FOD	O	Focus driver output (PWM output)	
80	TRD	O	Tracking driver output (PWM output)	

ADJUSTMENT

1. IC10 (TDA7513) -The Tuner adjustment method

- When IC10 and its circumference are fixed, according to the following order, it readjusts if needed.
- The adjustment item changes with parts to exchange. Please refer to "Parts vs Adjustment item table".

1-1. VCO Coil Adjustment -Adjustment of Tuning Voltage

Voltage Check Point : Vt-Check Land
(PWB Side_B, around D506)

Adjustment Coil : L507 (VCO Coil)

The adjustment method : VCO coil is turned and adjusted according to the following tables.

Type	Mode	Freq.	Voltage	Fig.
E/M	AM	1611kHz	5.5±0.1(V)	(C)
K	AM	1700kHz	5.8±0.1(V)	(C)
J	FM	90.0MHz	5.6±0.1(V)	(C)
W (Wide Band)	FM	108.0MHz	7.2±0.1(V)	(C)

M : AM Adjustment

For Your Information : The frequency of SET is only set up by Pre-Set-Key in case this adjustment

1-2. Adjustment of 1st & 2nd-MIX Coil

Voltage Check Point : S_METER-Check Land
(PWB Side_B, around W572)

Adjustment Coil : 1st IFT=L508 / 2nd IFT=L509

Setting of Signal Generator : Refer to the following tables

Type	Mode	Freq.	Mod.	ANT Input	Fig.
K	AM	1000kHz	OFF	35dBμEMF	(B),(C)
E,M,J,W	AM	999kHz	OFF	35dBμEMF	(B),(C)

- ① The appearance and the coil with which S-METER DC voltage serves as the maximum are turned and adjusted in the above-mentioned SG input.
- ② By the above-mentioned adjustment method, same adjustment is performed to both sides (1st & 2nd MIX Coil).

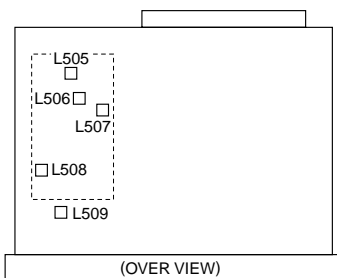
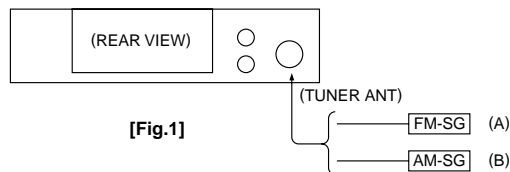

[Fig.2]

1-3. Adjustment of FM_ANT & RF Coil

Voltage Check Point : S_METER-Check Land
(PWB Side_B, around W572)

Adjustment Coil : ANT_Coil=L505
RF_Coil=L506

Setting of Signal Generator : Refer to the following tables

Type	Mode	Freq.	Mod.	ANT Input	Fig.
E/M	FM	87.5MHz	OFF	5 or 11dBμEMF	(A),(C)
K	FM	87.9MHz	OFF	5 or 11dBμEMF	(A),(C)
J	FM	76.0MHz	OFF	5 or 11dBμEMF	(A),(C)
W (Wide Band)	FM	65.0MHz	OFF	5 or 11dBμEMF	(A),(C)

- ① The appearance and the coil with which S-METER DC voltage serves as the maximum are turned and adjusted in the above-mentioned SG input.
- ② By the above-mentioned adjustment method, same adjustment is performed to both sides (ANT & RF Coil).

1-4. Adjustment of STEREO (adjustment of 456k-VCO)

Adjust in TEST_MODE

- How to enter the test mode
While pressing on [FM] and [PRESET 6] keys, reset the unit.
- Adjustment method
Complete on condition that show "ALL OFF" when pressing on [PRESET 1] and [PRESET 6] keys. (Writing adjustment value to the EEPROM.)
Effect of adjustment is in cofirmation of adjustment status at [PRESET 4] key.
- Display of [PRESET 4]
Adjustment "OK"
: 14 seg model "E2P OK", 7 seg model "EPO"
Adjustment "NG"
: 14 seg model "E2P ERR", 7 seg model "EPE"
- Releasing the test mode
Reset mode only.
ACC off, Power off, Power down and Remove the panel mode is not releasing.

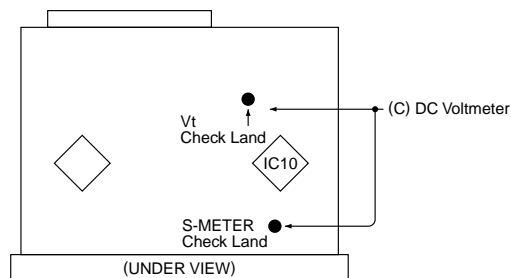

[Fig.3]

ADJUSTMENT

2. IC10 (TDA7513) Replacement -Parts vs Adjustment Item Table

- When the parts in the following tables are exchanged, please readjust according to a table.
- When other parts are exchanged, please perform only a check of operation. There is no necessity for readjustment.

Replacement parts				Adjustment Item					
Parts Name	Ref Number	TYPE	Parts Number	VCOVt	1st MIX	2nd MIX	ANT Coil	RF Coil	Stereo
	IC10	ALL	TDA7513	○	○	○	○	○	○
EEP-ROM	IC12	ALL	M24C01-WMN6T BR24C01AF-W S-24CS02AFJ-TB	○	○	○	○	○	○
Antenna Coil	L505	J E,K,M W (Wide Band)	L31-0966-05 L31-0967-05 L31-0968-05				○		
RF Coil	L506	J E,K,M W (Wide Band)	L31-0969-05 L31-0970-05 L31-0971-05					○	
VCO Coil	L507	J E,K,M W (Wide Band)	L32-0932-05 L32-0933-05 L32-0934-05	○	○	○	○	○	
1st MIX Coil	L508	ALL	L30-0770-05		○				
2nd MIX Coil	L509	ALL	L30-0771-05			○			
Variable Capacitance Diodes	D504	J,E,K,M W (Wide Band)	KV1720S KV1735S	○	○	○	○	○	
Variable Capacitance Diodes	D505	J,E,K,M W (Wide Band)	KV1720S KV1735S	○	○	○	○	○	
Variable Capacitance Diodes	D506	J,E,K,M W (Wide Band)	KV1720S KV1735S	○	○	○	○	○	
X'tal	X501	ALL	L77-2077-05						

The "○" mark shows that the adjustment is need.

KDC-1022/122P

PC BOARD (COMPONENT SIDE VIEW)

CD PLAYER UNIT X32-5380-00 (J74-1485-12)

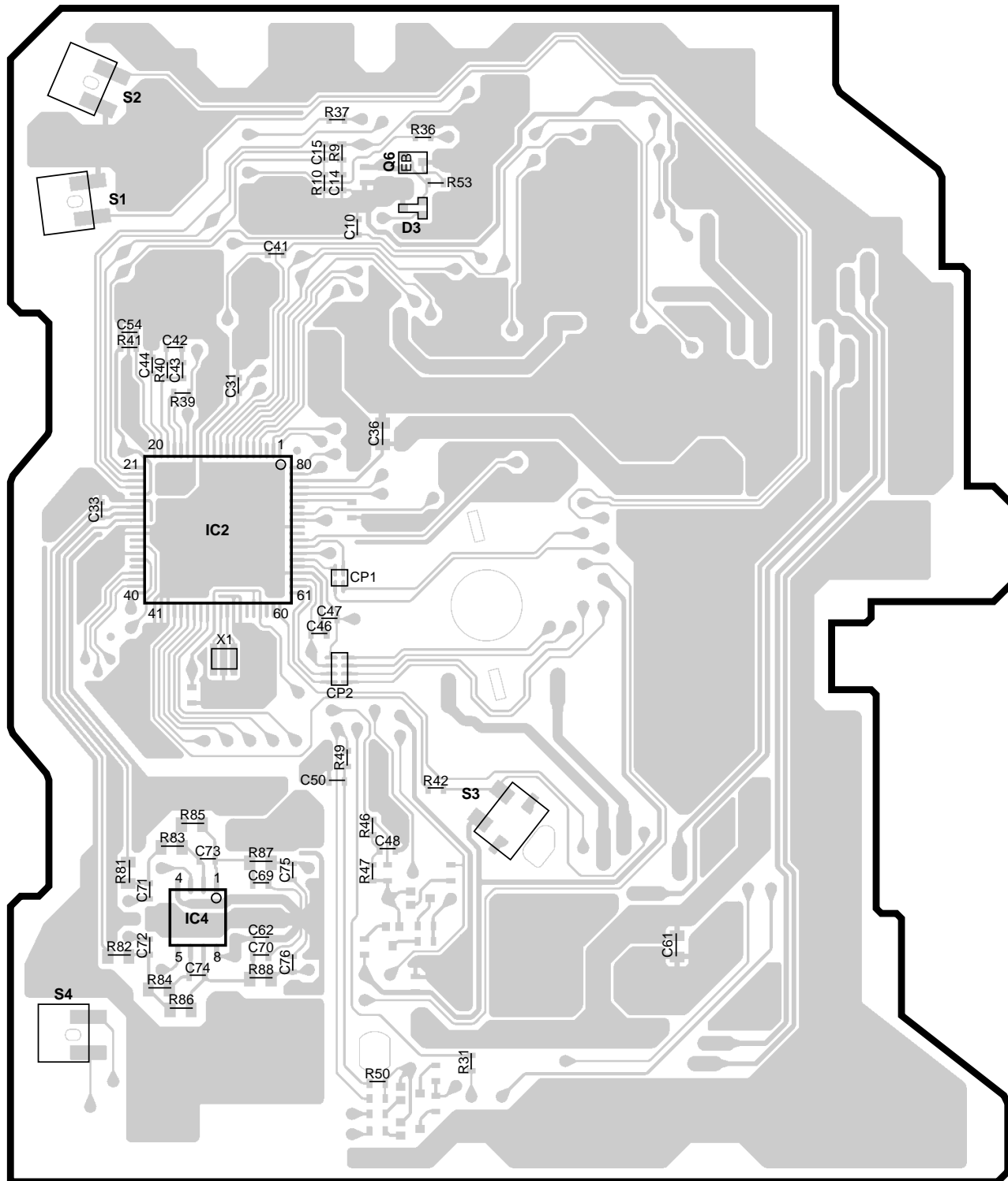

Refer to the schematic diagram for the values of resistors and capacitors.

X32-5380-00

Ref No.	Address
IC2	4B
Q6	2C

PC BOARD (FOIL SIDE VIEW)

CD PLAYER UNIT X32-5380-00 (J74-1485-12)

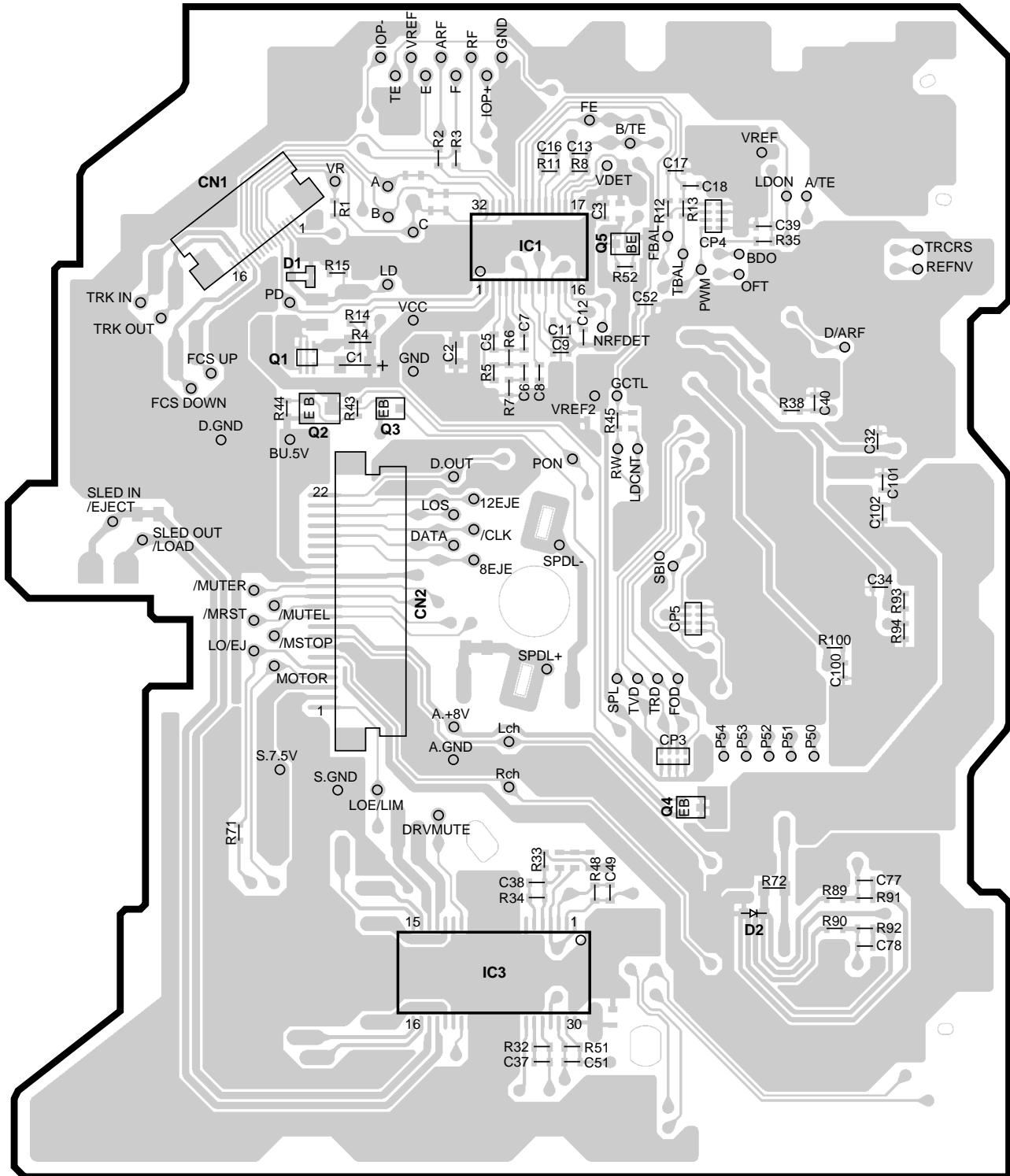

X32-5380-00

Ref No.	Address	Ref No.	Address
IC1	2H	Q3	3G
IC3	5H	Q4	5I
Q1	3G	Q5	2H
Q2	3G		

Refer to the schematic diagram for the values of resistors and capacitors.

KDC-1022/122P PC BOARD (FOIL SIDE VIEW)

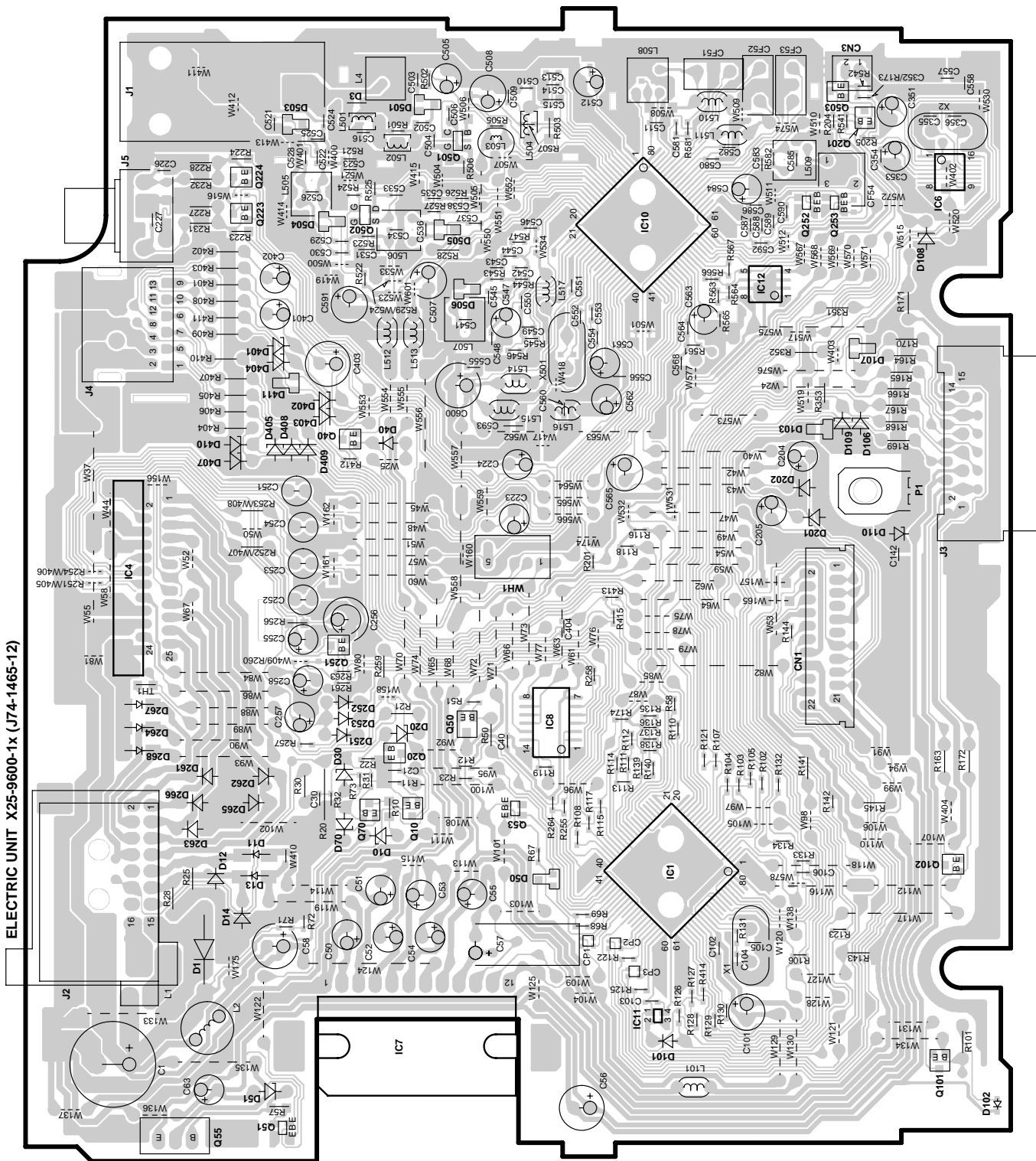

X25-9600-1x

Ref No.	Address	Ref No.	Address	Ref No.	Address	Ref No.	Address	Ref No.	Address
IC1	5N	IC10	2N	Q20	4M	Q55	6L	Q251	4L
IC4	4K	IC11	6N	Q40	3L	Q70	5L	Q501	2M
IC7	6M	IC12	2N	Q50	4M	Q223	2L	Q502	2L
IC8	4M	Q10	5M	Q51	6L	Q224	2L		

Refer to the schematic diagram for the values of resistors and capacitors.

PC BOARD (COMPONENT SIDE VIEW)

(FOIL SIDE VIEW)

SWITCH UNIT X16-2370-1x (J74-1285-32)

SWITCH UNIT X16-2370-1x (J74-1285-32)

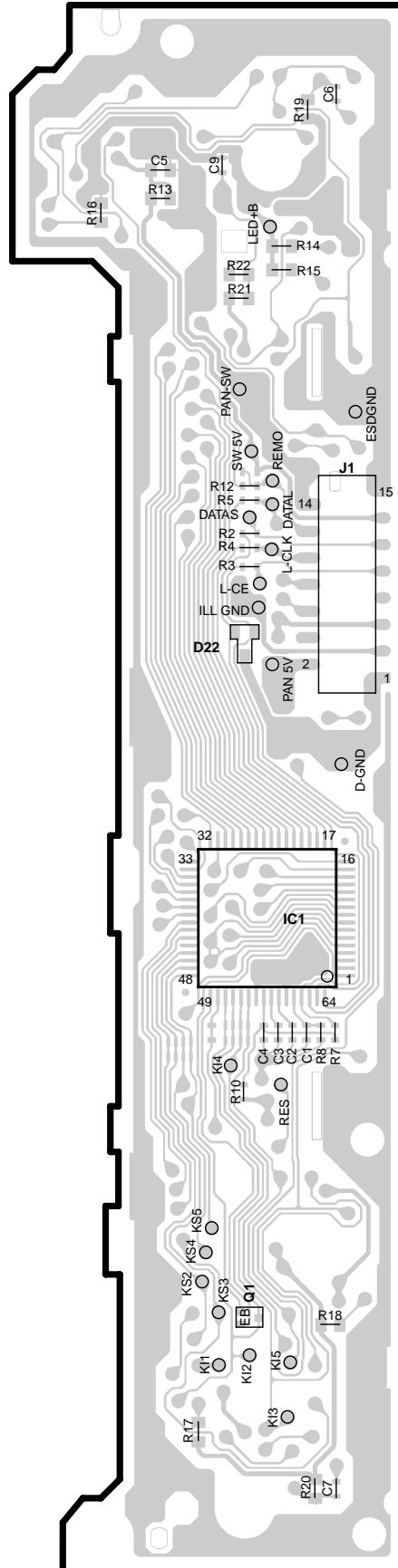
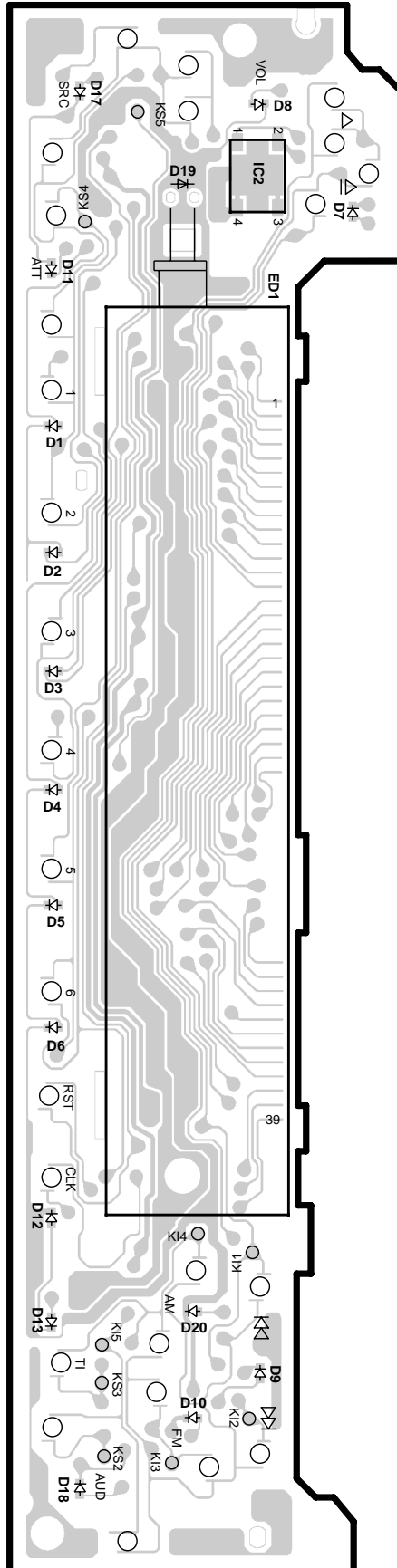

X16-2370-1x

Ref No.	Address
IC1	5S
Q1	6S

Refer to the schematic diagram for the values of resistors and capacitors.

KDC-1022/122P

CD PLAYER UNIT (X32-5380-00)

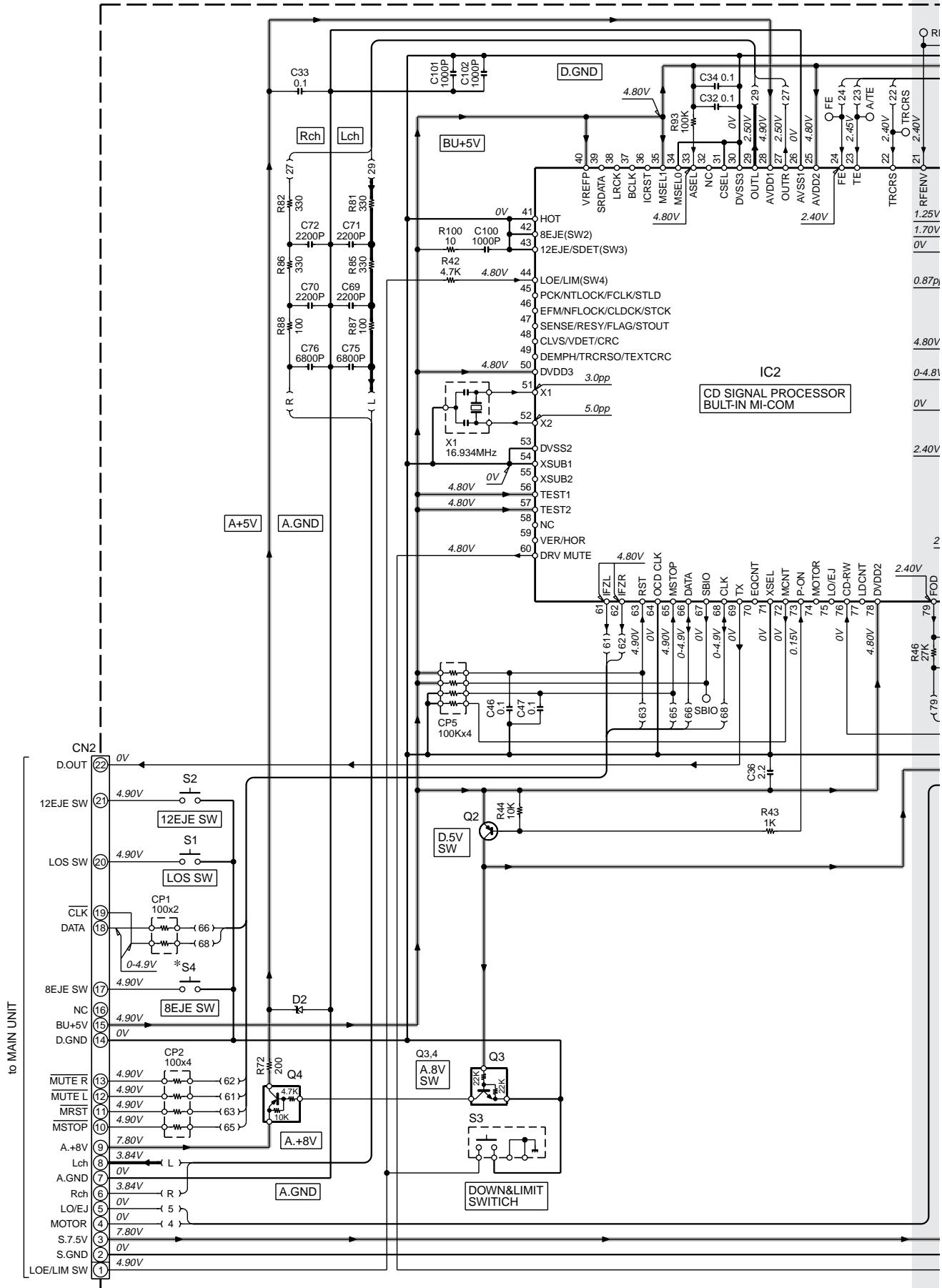

KDC-1022/122P

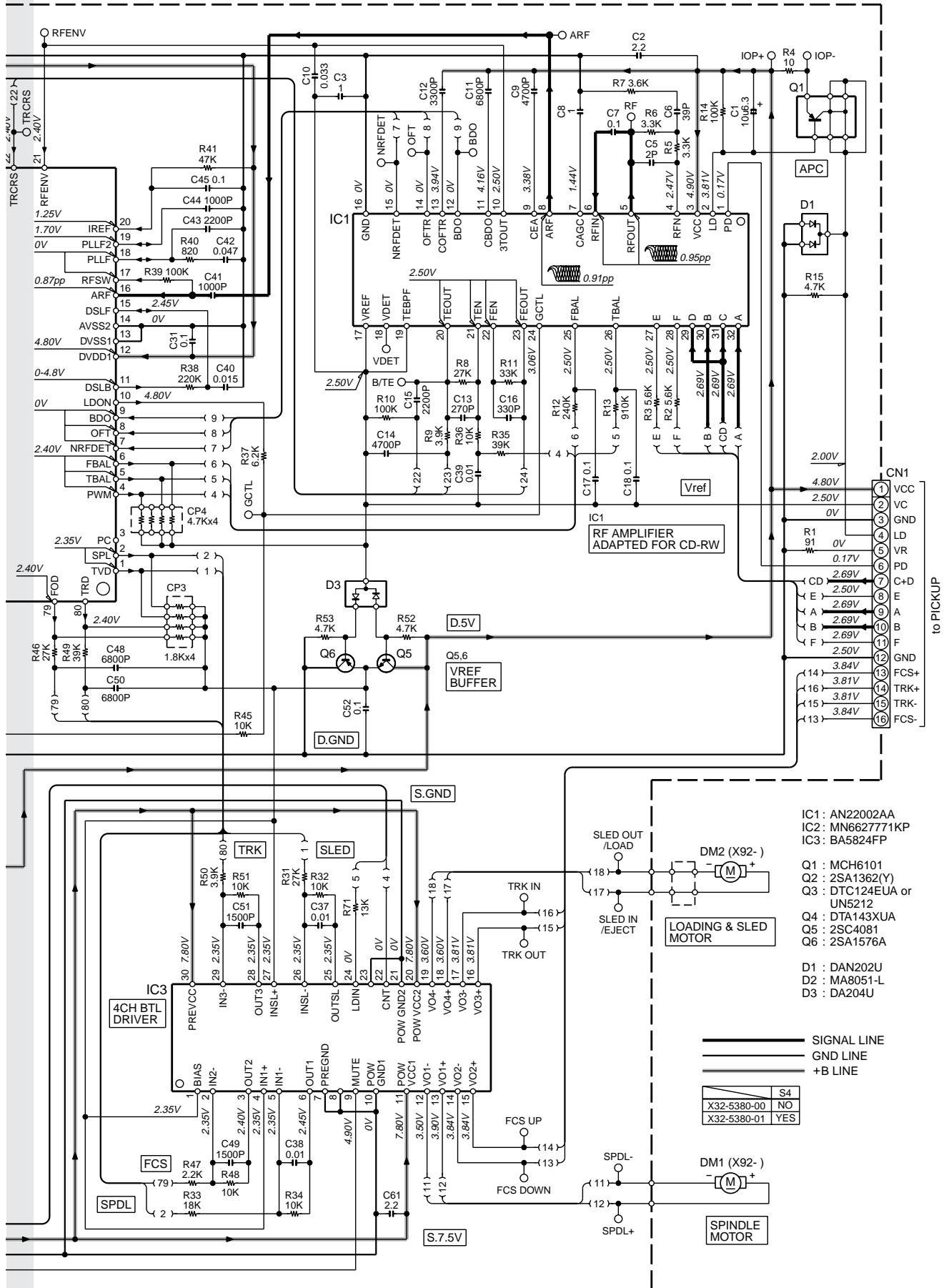

CAUTION : For continued safety, replace safety critical components only with manufacturer's recommended parts (refer to parts list).
 ⚠ Indicates safety critical components. To reduce the risk of electric shock, leakage-current or resistance measurements shall be carried out (exposed parts are acceptably insulated from the supply circuit) before the appliance is returned to the customer.

- DC voltages are as measured with a high impedance voltmeter. Values may vary slightly due to variations between individual instruments or/and units.

KDC-1022/122P

CAUTION : For continued safety, replace safety critical components only with manufacturer's recommended parts (refer to parts list).

⚠ Indicates safety critical components. To reduce the risk of electric shock, leakage-current or resistance measurements shall be carried out (exposed parts are acceptably insulated from the supply circuit) before the appliance is returned to the customer.

- DC voltages are as measured with a high impedance voltmeter. Values may vary slightly due to variations between individual instruments or/and units.

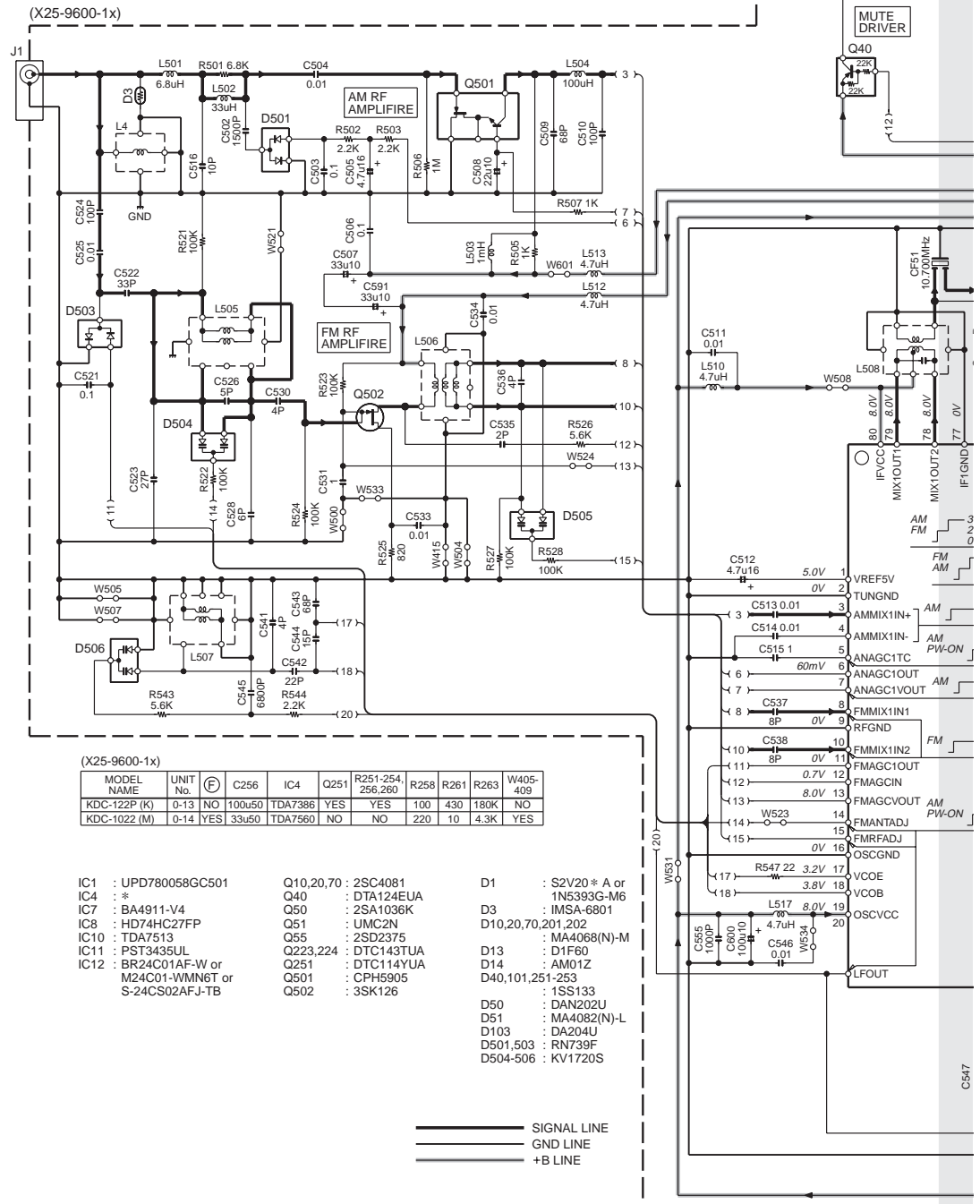
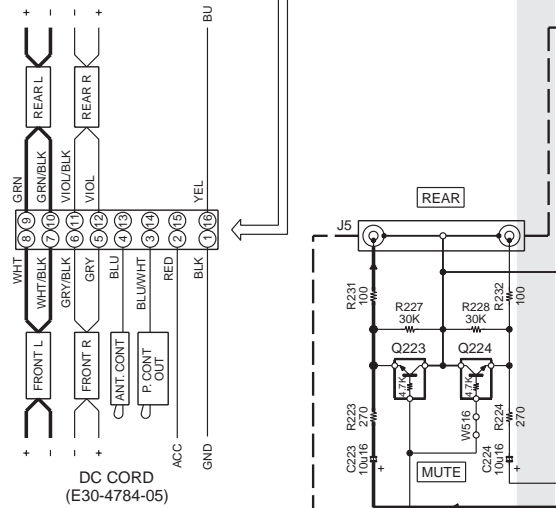

KDC-1022/122P

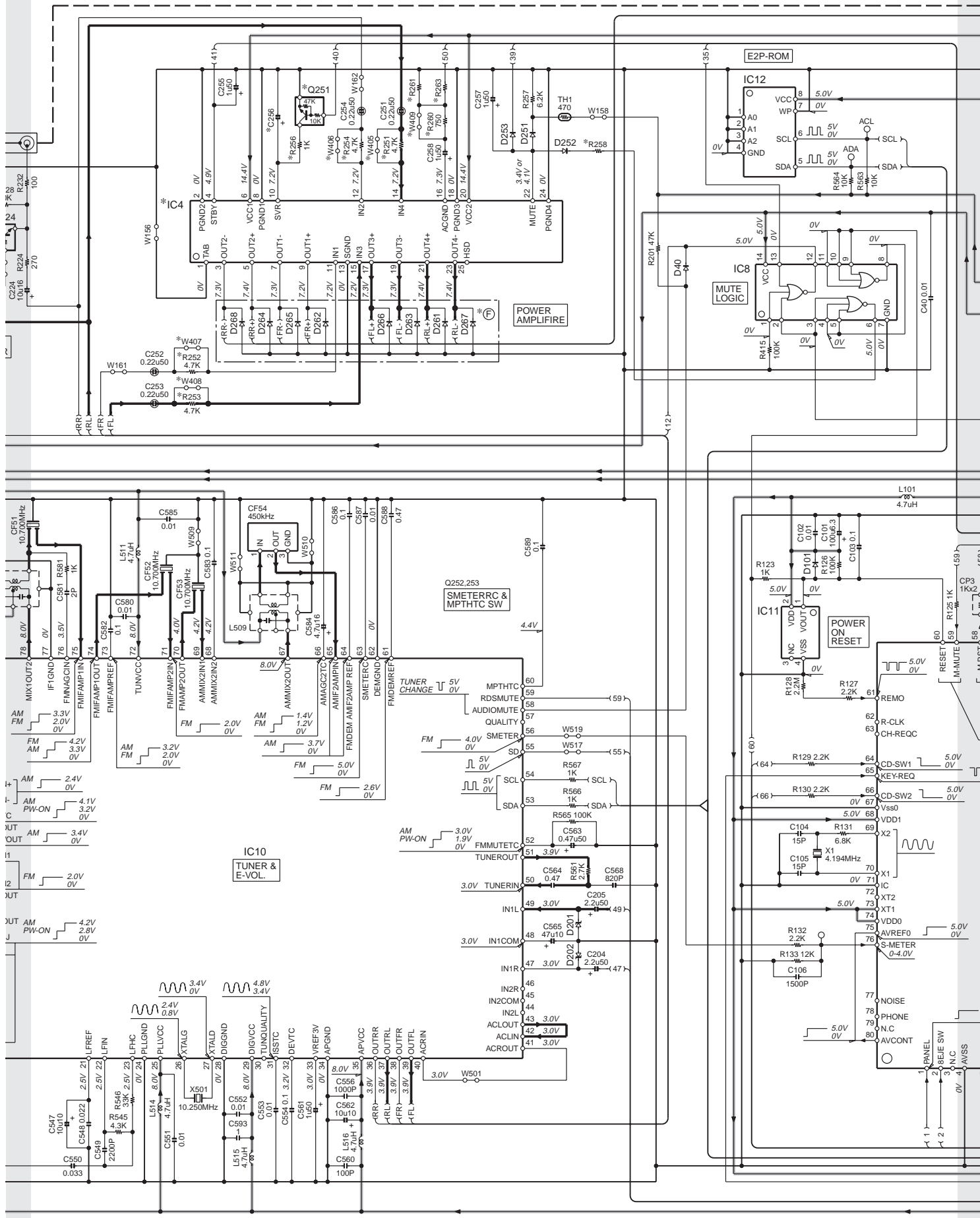

KDC-1022/122P

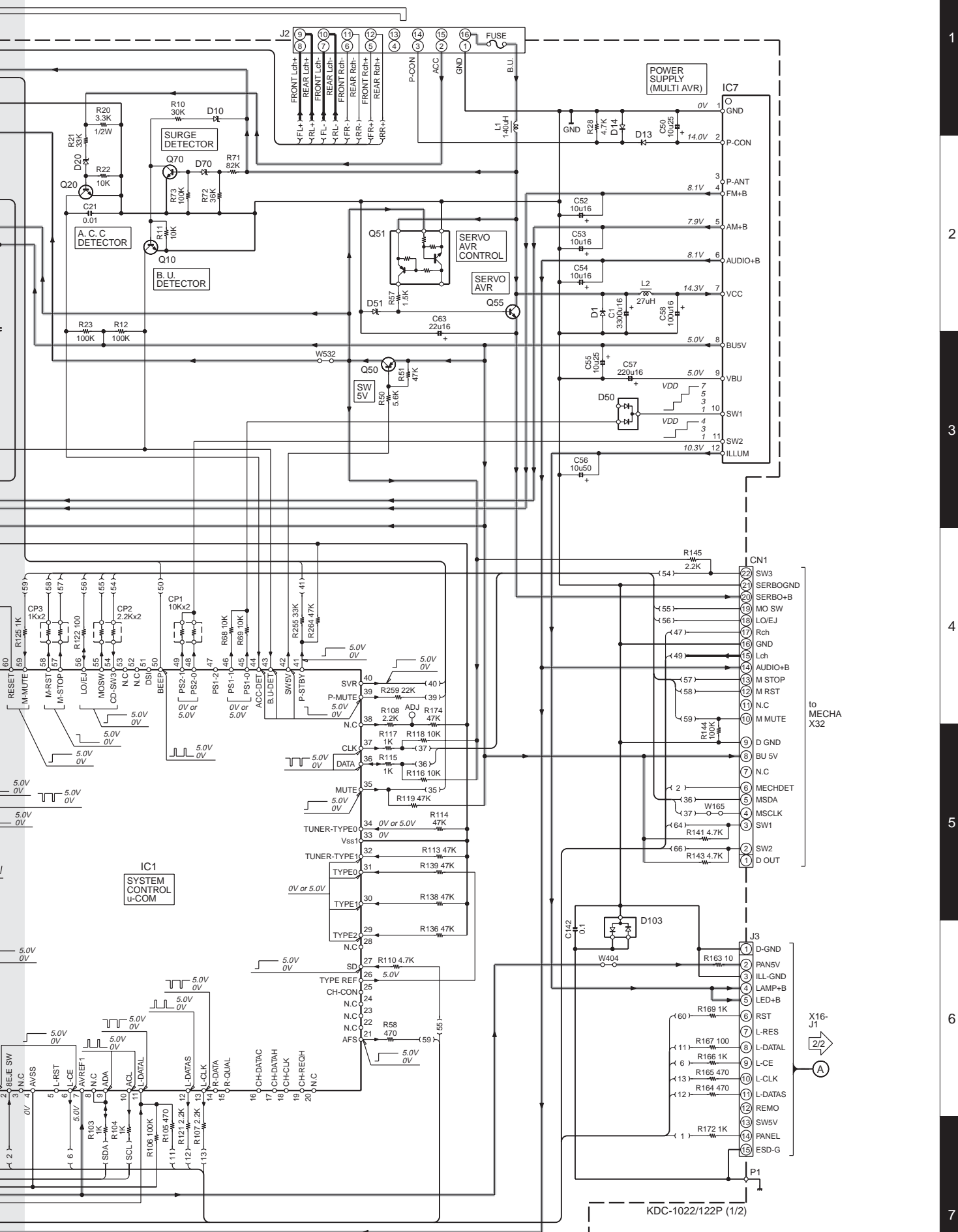

1
2
3
4
5
6
7

KDC-1022/122P (1/2)

KDC-1022/122P

SWITCH UNIT (X16-2370-1x)

(B38-1079-05) : KDC-1022
(B38-1132-05) : KDC-122P

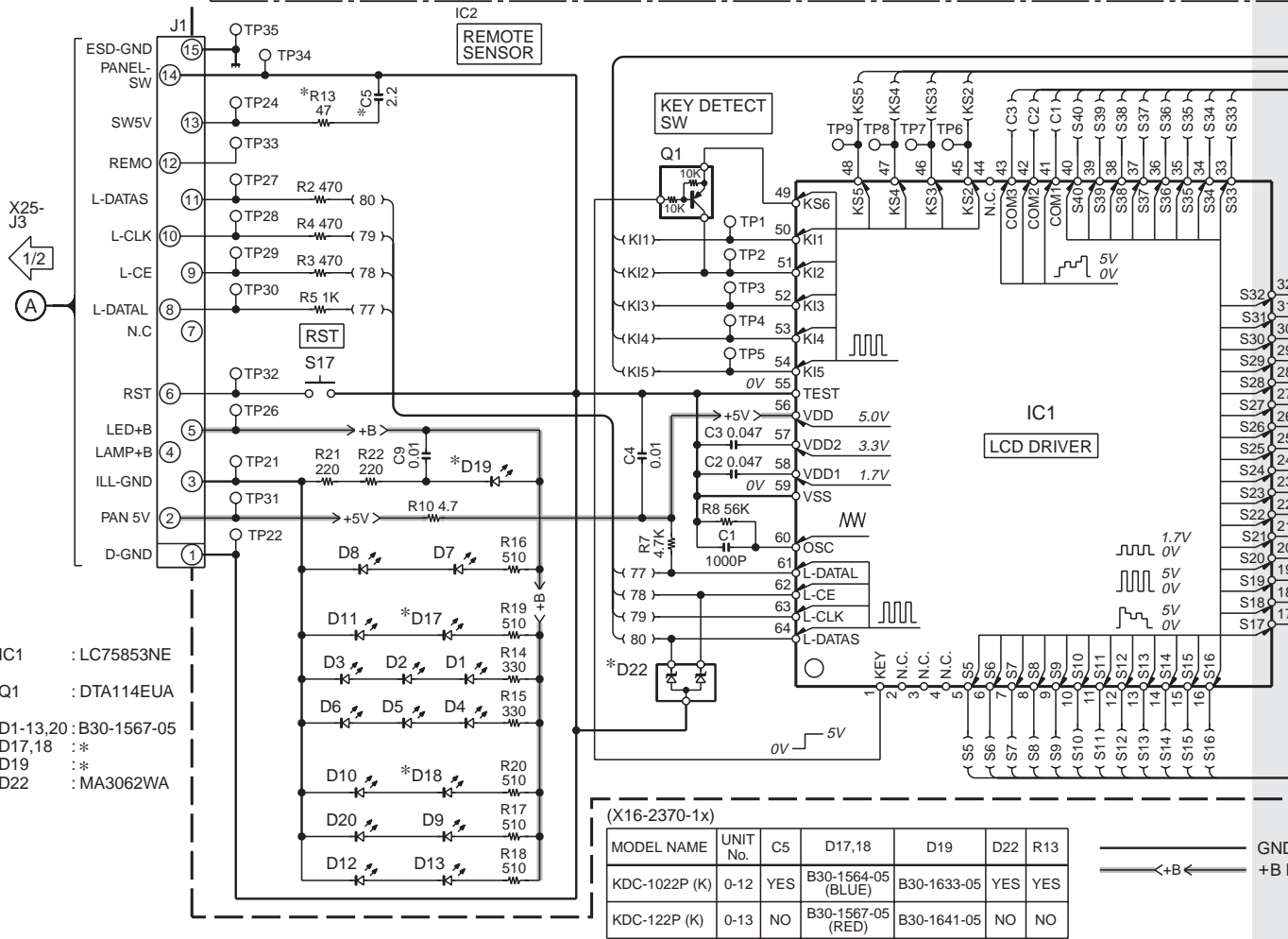
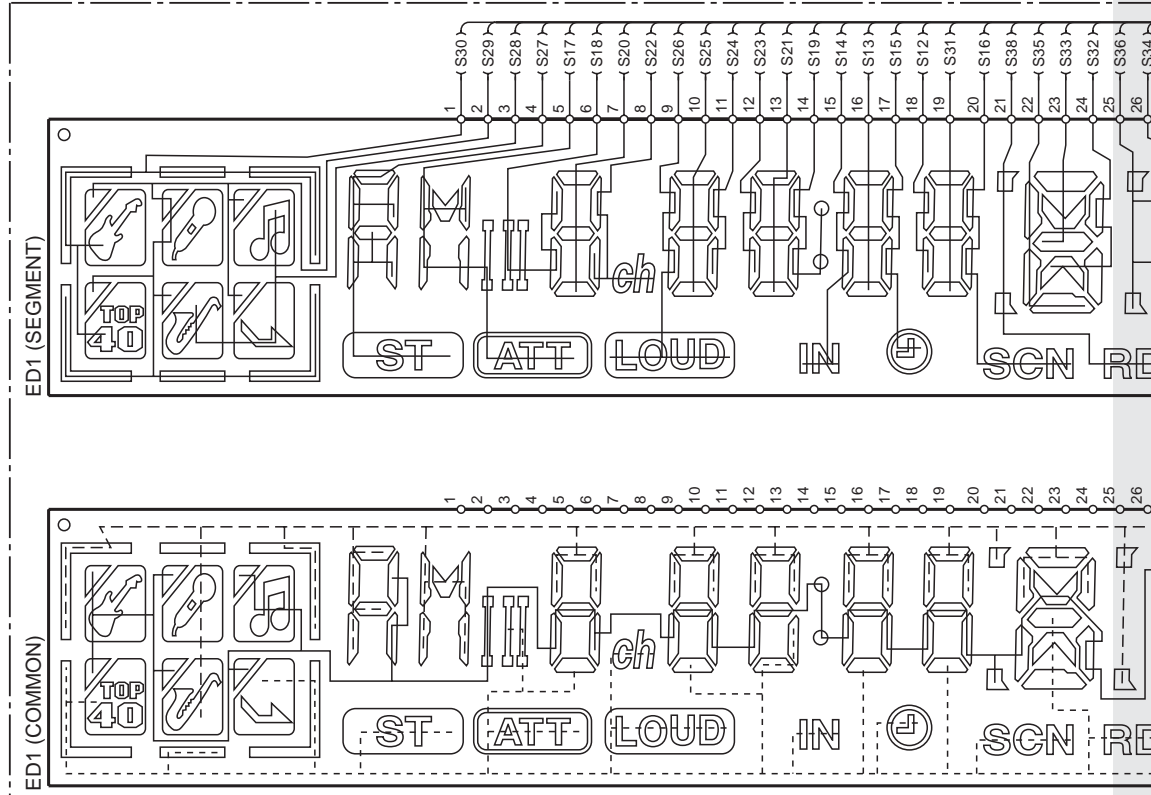

- IC1 : LC75853NE
- Q1 : DTA114EUA
- D1-13,20 : B30-1567-05
- D17,18 : *
- D19 : *
- D22 : MA3062WA

(X16-2370-1x)

MODEL NAME	UNIT No.	C5	D17,18	D19	D22	R13
KDC-1022P (K)	0-12	YES	B30-1564-05 (BLUE)	B30-1633-05	YES	YES
KDC-122P (K)	0-13	NO	B30-1567-05 (RED)	B30-1641-05	NO	NO

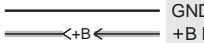

KDC-1022/122P

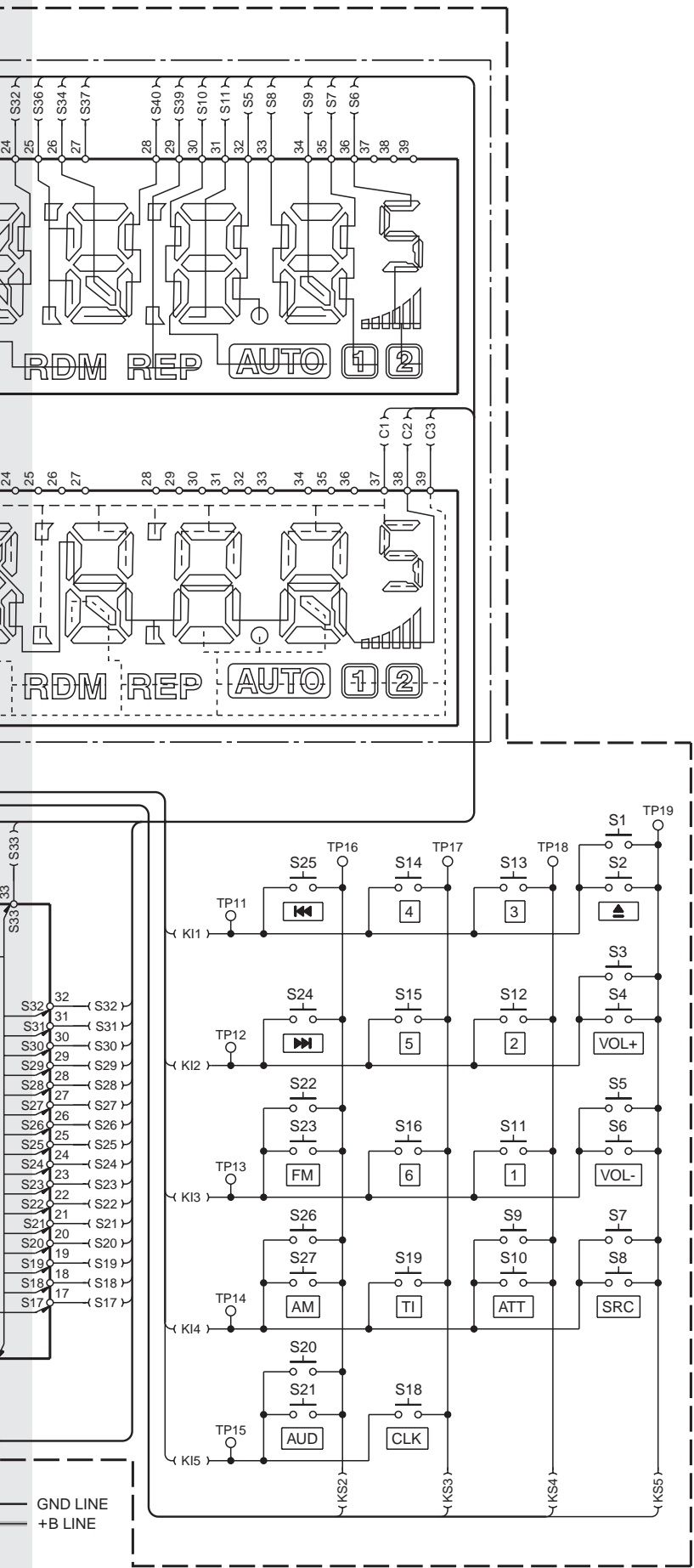

DTC114YUA
DTC143TUA
UN5111
2SA1036K
2SA1362
2SA1576A



2SC4081

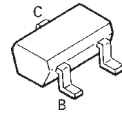

DTA114EUA
DTA124EUA
DTC124EUA

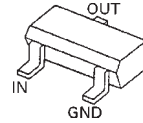

UMC2N

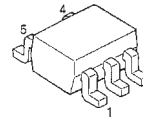

DAN202U



DA204U



MA142WK
UN5212



3SK126

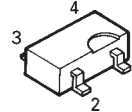

BR24C01AF-W

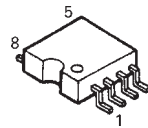

MCH6101

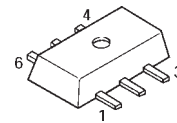

CAUTION : For continued safety, replace safety critical components only with manufacturer's recommended parts (refer to parts list).
 ▲ Indicates safety critical components. To reduce the risk of electric shock, leakage-current or resistance measurements shall be carried out (exposed parts are acceptably insulated from the supply circuit) before the appliance is returned to the customer.

- DC voltages are as measured with a high impedance voltmeter. Values may vary slightly due to variations between individual instruments or/and units.

1
2
3
4
5
6
7

EXPLODED VIEW (MECHANISM)

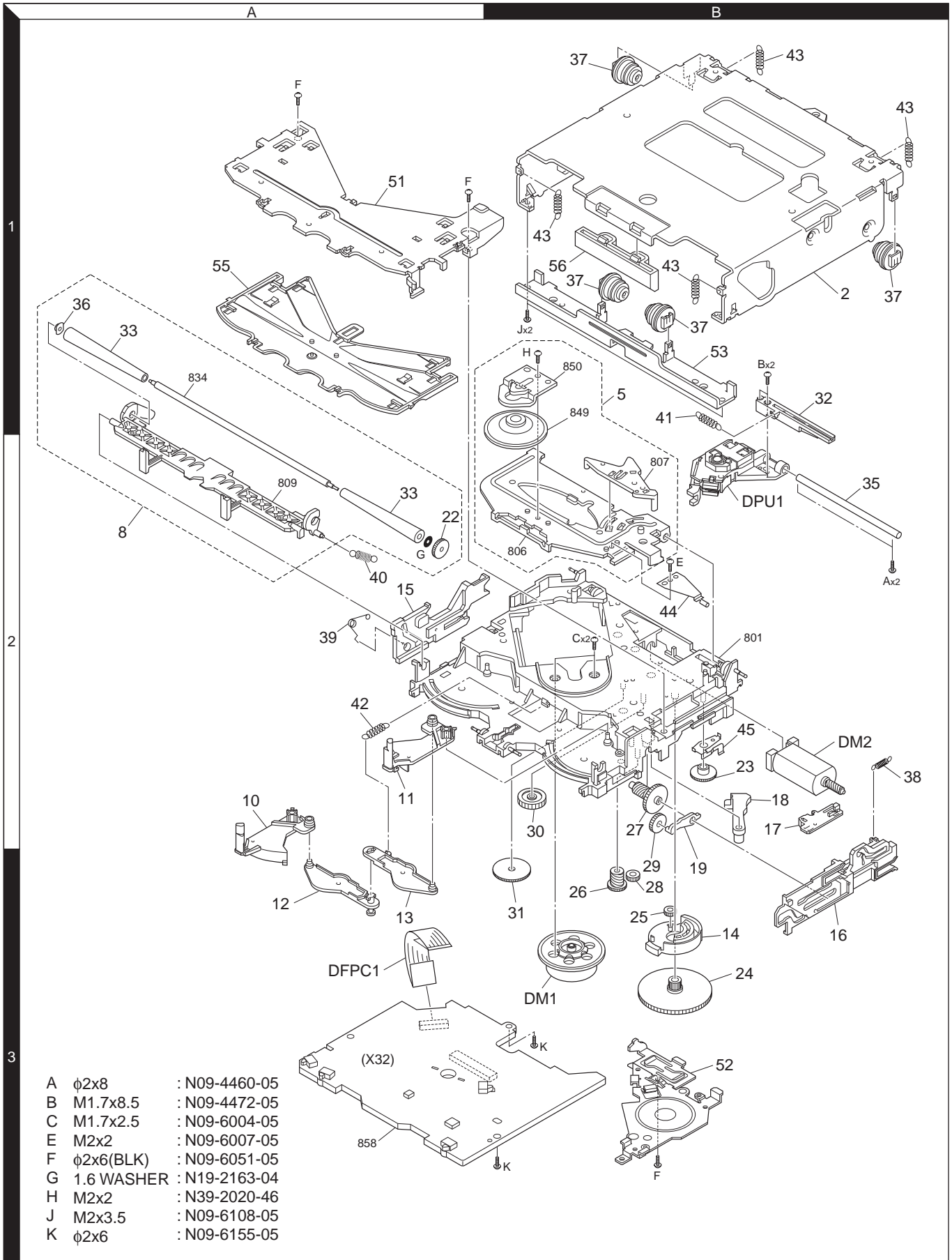

Refer to the service manual X92-4030-0x (B51-7867-00) for CD mechanism operation.

EXPLODED VIEW (UNIT)

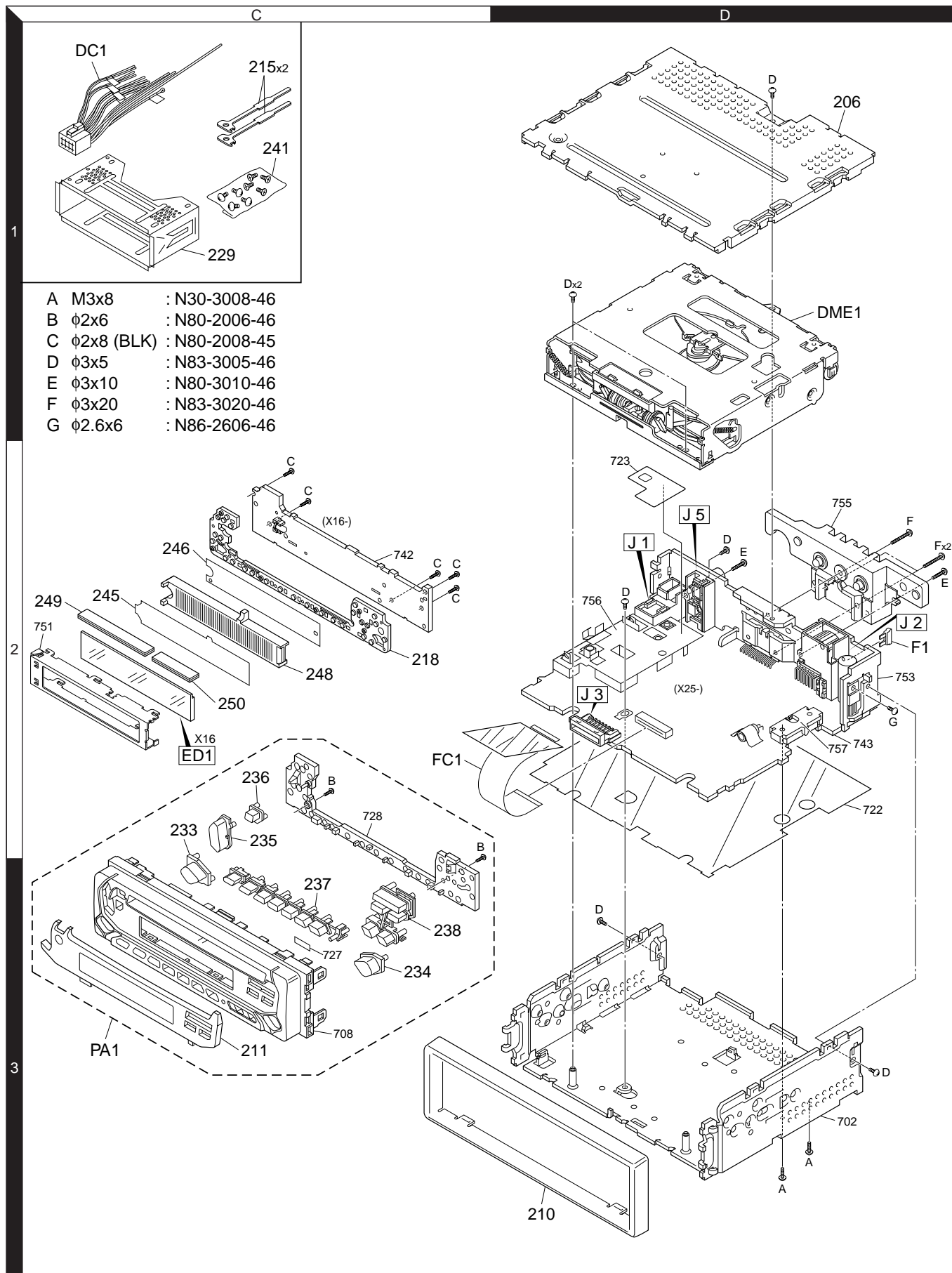

PARTS LIST

* New parts

Parts without **Parts No.** are not supplied.

Les articles non mentionnés dans le **Parts No.** ne sont pas fournis.

Teile ohne **Parts No.** werden nicht geliefert.

Ref. No.	Add	New	Parts No.	Description	Destination
KDC-1022/122P					
206	1D		A52-0804-02	TOP PLATE	
PA1	3C	*	A64-3135-02	PANEL ASSY	K
PA1	3C	*	A64-3136-02	PANEL ASSY	K1
-			B46-0100-50	WARRANTY CARD	
-			B58-1365-04	CAUTION CARD	
-		*	B64-2634-00	INST.MANUAL (ENG.FRE.SPA.POR.)	
210	3D		B07-3022-02	ESCUTCHEON	K1
210	3D		B07-3060-02	ESCUTCHEON	K
211	3C	*	B10-4436-01	FRONT GLASS	K
211	3C	*	B10-4437-01	FRONT GLASS	K1
215	1C		D10-4589-04	LEVER	
218	2C		E29-1872-02	CONDUCTIVE RUBBER	
△ DC1	1C		E30-4784-05	DC CORD	
FC1	2D		E39-0476-05	FLAT CABLE	
△ F1	2D		F52-0006-05	FUSE (MINI BLADE TYPE)	
-			H10-4856-12	POLYSTYRENE FOAMED FIXTURE	
-			H25-0329-04	PROTECTION BAG (280X450X0.03)	
-			H25-0337-04	PROTECTION BAG (180X300X0.03)	
-		*	H54-2947-03	ITEM CARTON CASE	K
-		*	H54-2948-03	ITEM CARTON CASE	K1
229	1C		J21-9716-03	MOUNTING HARDWARE ASSY	
233	3C		K24-3823-04	KNOB (RELEASE)	
234	3C		K24-3824-04	KNOB (SRC)	
235	3C		K24-3825-03	KNOB (AUD)	
236	2C		K24-3826-04	KNOB (VOL)	
237	3C		K25-1396-03	KNOB (EJECT)	
238	3C		K25-1397-03	KNOB (PRE1-6,ATT,RESET)	
241	1C		N99-1719-05	SCREW SET	
A	3D		N30-3008-46	PAN HEAD MACHINE SCREW	
B	3C		N80-2006-46	PAN HEAD TAPTITE SCREW	
C	2C		N80-2008-45	PAN HEAD TAPTITE SCREW	
D	1D		N83-3005-46	PAN HEAD TAPTITE SCREW	
DME1	1D		X92-4640-00	MECHANISM ASSY	
SWITCH UNIT (X16-2370-1x)					
245	2C		B11-1358-04	OPTICAL DIFFUSER	K
245	2C		B11-1372-04	OPTICAL DIFFUSER	K1
246	2C		B11-1359-04	REFLECTION SHEET	
248	2C		B19-2130-03	LIGHTING BOARD	
D1-13			B30-1567-05	LED (RED)	
D17,18			B30-1564-05	LED (BLUE)	K
D17,18			B30-1567-05	LED (RED)	K1
D19			B30-1633-05	LED (WHITE)	K
D19			B30-1641-05	LED	K1
D20			B30-1567-05	LED (RED)	
ED1			B38-1079-05	LIQUID CRYSTAL (MONO)	K
ED1		*	B38-1132-05	LIQUID CRYSTAL (POSI)	K1
C1			CK73GB1H102K	CHIP C 1000PF	K
C2,3			CK73GB1E473K	CHIP C 0.047UF	K

Ref. No.	Add	New	Parts No.	Description	Destination
C2,3			CK73GB1H473K	CHIP C 0.047UF	K
C4			CK73GB1H103K	CHIP C 0.010UF	K
C5			CK73FB1A225K	CHIP C 2.2UF	K
C9			CK73GB1H103K	CHIP C 0.010UF	K
249	2C		E29-1956-04	CONDUCTIVE RUBBER	
250	2C		E29-1957-04	CONDUCTIVE RUBBER	
J1			E59-0828-05	RECTANGULAR PLUG (15P)	
-			J19-5130-04	LED HOLDER	
R2-4			RK73GB2A471J	CHIP R 470 J 1/10W	
R5			RK73GB2A102J	CHIP R 1.0K J 1/10W	
R7			RK73GB2A472J	CHIP R 4.7K J 1/10W	
R8			RK73GB2A563J	CHIP R 56K J 1/10W	
R10			RK73GB2A4R7J	CHIP R 4.7 J 1/10W	
R13			RK73FB2B470J	CHIP R 47 J 1/8W	K
R14,15			RK73FB2B331J	CHIP R 330 J 1/8W	
R16-20			RK73FB2B511J	CHIP R 510 J 1/8W	
R21,22			RK73FB2B221J	CHIP R 220 J 1/8W	
D22			MA3062WA	ZENER DIODE	K
IC1			LC75853NE	MOS-IC	
Q1			DTA114EUA	DIGITAL TRANSISTOR	
Q1			UN5111	TRANSISTOR	
ELECTRIC UNIT (X25-9600-1x)					
C1		*	C94-0216-05	ELECTRO 3300UF	16WV
C21			CK73GB1H103K	CHIP C 0.010UF	K
C40			CK73GB1H103K	CHIP C 0.010UF	K
C50		*	C94-0045-05	ELECTRO 10UF	25WV
C52-54		*	C94-0039-05	ELECTRO 10UF	16WV
C55		*	C94-0045-05	ELECTRO 10UF	25WV
C56		*	CD04AT1H100M	ELECTRO 10UF	50WV
C57			C90-2980-05	ELECTRO 220UF	16WV
C58			C90-2962-05	ELECTRO 100UF	16WV
C63		*	C94-0040-05	ELECTRO 22UF	16WV
C101		*	C94-0033-05	ELECTRO 100UF	6.3WV
C102			CK73GB1H103K	CHIP C 0.010UF	K
C103			CK73GB1C104K	CHIP C 0.10UF	K
C104,105			CC73GCH1H150J	CHIP C 15PF	J
C106			CK73GB1H152K	CHIP C 1500PF	K
C142			CK73GB1C104K	CHIP C 0.10UF	K
C204,205		*	C94-0052-05	ELECTRO 2.2UF	50WV
C223,224		*	C94-0039-05	ELECTRO 10UF	16WV
C251-254			C90-5296-05	NP-ELECT 0.22UF	50WV
C255		*	C94-0051-05	ELECTRO 1UF	50WV
C256		*	C94-0036-05	ELECTRO 33UF	10WV
C256		*	C94-0038-05	ELECTRO 100UF	10WV
C257		*	C94-0051-05	ELECTRO 1UF	50WV
C258		*	CD04AT1H010M	ELECTRO 1UF	50WV
C502			CK73GB1H152K	CHIP C 1500PF	K
C503			CK73GB1C104K	CHIP C 0.10UF	K
C504			CK73GB1H103K	CHIP C 0.010UF	K
C505		*	C94-0057-05	ELECTRO 4.7UF	16WV
C506			CK73GB1C104K	CHIP C 0.10UF	K
C507		*	CD04AT1A330M	ELECTRO 33UF	10WV
C508		*	CD04AT1A220M	ELECTRO 22UF	10WV

K : KDC-1022 K1 : KDC-122P

△ Indicates safety critical components.

PARTS LIST

* New parts

Parts without **Parts No.** are not supplied.

Les articles non mentionnés dans le **Parts No.** ne sont pas fournis.

Teile ohne **Parts No.** werden nicht geliefert.

ELECTRIC UNIT (X25-9600-1x)

Ref. No.	A d d	N e w	Parts No.	Description	Desti- nation
C509			CC73GCH1H680J	CHIP C 68PF J	
C510			CC73GCH1H101J	CHIP C 100PF J	
C511			CK73GB1H103K	CHIP C 0.010UF K	
C512		*	C94-0057-05	ELECTRO 4.7UF 16WV	
C513,514			CK73GB1H103K	CHIP C 0.010UF K	
C515			CK73FB1C105K	CHIP C 1.0UF K	
C516			CC73GCH1H100D	CHIP C 10PF D	
C521			CK73GB1C104K	CHIP C 0.10UF K	
C522			CC73GCH1H330J	CHIP C 33PF J	
C523			CC73GCH1H270J	CHIP C 27PF J	
C524			CC73GCH1H101J	CHIP C 100PF J	
C525			CK73GB1H103K	CHIP C 0.010UF K	
C526			CC73GCH1H050C	CHIP C 5.0PF C	
C528			CC73GCH1H060D	CHIP C 6.0PF D	
C530			CC73GCH1H040C	CHIP C 4.0PF C	
C531			CK73FB1C105K	CHIP C 1.0UF K	
C533,534			CK73GB1H103K	CHIP C 0.010UF K	
C535			CC73GCH1H020C	CHIP C 2.0PF C	
C536			CC73GCH1H040C	CHIP C 4.0PF C	
C537,538			CC73GCH1H080D	CHIP C 8.0PF D	
C541			CC73GCH1H040C	CHIP C 4.0PF C	
C542			CC73GCH1H220J	CHIP C 22PF J	
C543			CC73GCH1H680J	CHIP C 68PF J	
C544			CC73GCH1H150J	CHIP C 15PF J	
C545			CK73GB1H682K	CHIP C 6800PF K	
C546			CK73GB1H103K	CHIP C 0.010UF K	
C547		*	C94-0056-05	ELECTRO 10UF 10WV	
C548			CK73GB1E223K	CHIP C 0.022UF K	
C549			CK73GB1H222K	CHIP C 2200PF K	
C550			CK73GB1E333K	CHIP C 0.033UF K	
C551,552			CK73GB1H103K	CHIP C 0.010UF K	
C553,554			CK73GB1C104K	CHIP C 0.10UF K	
C555,556			CK73GB1H102K	CHIP C 1000PF K	
C560			CC73GCH1H101J	CHIP C 100PF J	
C561		*	C94-0065-05	ELECTRO 1UF 50WV	
C562		*	C94-0056-05	ELECTRO 10UF 10WV	
C563		*	C94-0064-05	ELECTRO 0.47UF 50WV	
C564			CK73GB1A474K	CHIP C 0.47UF K	
C565		*	C94-0037-05	ELECTRO 47UF 10WV	
C568			CC73GCH1H821J	CHIP C 820PF J	
C580			CK73GB1H103K	CHIP C 0.010UF K	
C581			CC73GCH1H020C	CHIP C 2.0PF C	
C582,583			CK73GB1C104K	CHIP C 0.10UF K	
C584		*	C94-0057-05	ELECTRO 4.7UF 16WV	
C585			CK73GB1H103K	CHIP C 0.010UF K	
C586			CK73GB1C104K	CHIP C 0.10UF K	
C587			CK73GB1H103K	CHIP C 0.010UF K	
C588			CK73GB1A474K	CHIP C 0.47UF K	
C589			CK73GB1C104K	CHIP C 0.10UF K	
C591		*	CD04AT1A330M	ELECTRO 33UF 10WV	
C593			CK73FB1C105K	CHIP C 1.0UF K	
C600		*	CD04AT1A101M	ELECTRO 100UF 10WV	
CN1			E40-9550-05	FLAT CABLE CONNECTOR (22P)	
J1			E04-0312-05	RF COAXIAL CABLE RECEPTACLE	

Ref. No.	A d d	N e w	Parts No.	Description	Desti- nation
J2			E58-0863-15	RECTANGULAR RECEPTACLE (DC)	
J3			E58-0880-05	RECTANGULAR RECEPTACLE (15P)	
J5			E63-0852-05	PIN JACK (2P)	
CF51-53			L72-0781-05	CERAMIC FILTER	
CF54			L72-0743-05	CERAMIC FILTER	
L1			L33-1170-05	CHOKO COIL ASSY	
L2			L33-1807-05	CHOKO COIL	
L4			L33-1123-05	LINE FILTER COIL	
L101			L40-4795-91	SMALL FIXED INDUCTOR 4.7UH	
L501			L40-6891-58	SMALL FIXED INDUCTOR	
L502			L40-3301-58	SMALL FIXED INDUCTOR 33U	
L503			L40-1021-56	SMALL FIXED INDUCTOR 1MH	
L504			L40-1011-58	SMALL FIXED INDUCTOR	
L505			L31-0967-05	FM-RF COIL	
L506			L31-0970-05	FM-RF COIL	
L507			L32-0936-05	FM OSCILLATING COIL	
L508			L30-0770-05	FM IFT	
L509			L30-0773-05	AM IFT	
L510-517			L40-4795-91	SMALL FIXED INDUCTOR 4.7UH	
X1			L77-1167-05	CRYSTAL RESONATOR 4.19M	
X501			L77-2077-05	CRYSTAL RESONATOR	
D	2D		N83-3005-46	PAN HEAD TAPTITE SCREW	
E	2D		N80-3010-46	PAN HEAD TAPTITE SCREW	
F	2D		N83-3020-46	PAN HEAD TAPTITE SCREW	
G	2D		N86-2606-46	BINDING HEAD TAPTITE SCREW	
CP1			R90-1049-05	MULTI-COMP 10K X2	
CP2			R90-1047-05	MULTI-COMP 2.2K X2	
CP3			R90-1046-05	MULTI-COMP 1K X2	
R10			RK73FB2B303J	CHIP R 30K J 1/8W	
R11			RK73GB2A103J	CHIP R 10K J 1/10W	
R12			RK73GB2A104J	CHIP R 100K J 1/10W	
R20			RD14DB2H332J	SMALL-RD 3.3K J 1/2W	
R21			RD14BB2C333J	RD 33K J 1/6W	
R22			RK73GB2A103J	CHIP R 10K J 1/10W	
R23			RK73GB2A104J	CHIP R 100K J 1/10W	
R28			RD14BB2C472J	RD 4.7K J 1/6W	
R50			RD14BB2C562J	RD 5.6K J 1/6W	
R51			RK73GB2A473J	CHIP R 47K J 1/10W	
R57			RK73FB2B152J	CHIP R 1.5K J 1/8W	
R58			RK73GB2A471J	CHIP R 470 J 1/10W	
R68,69			RK73GB2A103J	CHIP R 10K J 1/10W	
R71			RK73GB2A823J	CHIP R 82K J 1/10W	
R72			RK73GB2A363J	CHIP R 36K J 1/10W	
R73			RK73GB2A104J	CHIP R 100K J 1/10W	
R103,104			RK73GB2A102J	CHIP R 1.0K J 1/10W	
R105			RK73GB2A471J	CHIP R 470 J 1/10W	
R106			RK73GB2A104J	CHIP R 100K J 1/10W	
R107,108			RK73GB2A222J	CHIP R 2.2K J 1/10W	
R110			RK73GB2A472J	CHIP R 4.7K J 1/10W	
R113,114			RK73GB2A473J	CHIP R 47K J 1/10W	
R115			RK73GB2A102J	CHIP R 1.0K J 1/10W	
R116			RK73GB2A103J	CHIP R 10K J 1/10W	
R117			RK73GB2A102J	CHIP R 1.0K J 1/10W	
R118			RK73GB2A103J	CHIP R 10K J 1/10W	

PARTS LIST

* New parts

Parts without **Parts No.** are not supplied.

Les articles non mentionnés dans le **Parts No.** ne sont pas fournis.

Teile ohne **Parts No.** werden nicht geliefert.

ELECTRIC UNIT (X25-9600-1x)

Ref. No.	Add	New	Parts No.	Description	Destination	Ref. No.	Add	New	Parts No.	Description	Destination
R119			RK73GB2A473J	CHIP R 47K J 1/10W		R528			RD14BB2C104J	RD 100K J 1/6W	
R121			RK73GB2A222J	CHIP R 2.2K J 1/10W		R543			RK73GB2A562J	CHIP R 5.6K J 1/10W	
R122			RK73GB2A101J	CHIP R 100 J 1/10W		R544			RK73GB2A222J	CHIP R 2.2K J 1/10W	
R123			RK73GB2A102J	CHIP R 1.0K J 1/10W		R545			RK73GB2A432J	CHIP R 4.3K J 1/10W	
R125			RK73GB2A102J	CHIP R 1.0K J 1/10W		R546			RK73GB2A333J	CHIP R 33K J 1/10W	
R126			RK73GB2A104J	CHIP R 100K J 1/10W		R547			RK73GB2A220J	CHIP R 22 J 1/10W	
R127			RK73GB2A222J	CHIP R 2.2K J 1/10W		R561			RK73GB2A272J	CHIP R 2.7K J 1/10W	
R128			RK73GB2A225J	CHIP R 2.2M J 1/10W		R563,564			RK73GB2A103J	CHIP R 10K J 1/10W	
R129,130			RK73GB2A222J	CHIP R 2.2K J 1/10W		R565			RK73GB2A104J	CHIP R 100K J 1/10W	
R131			RK73GB2A682J	CHIP R 6.8K J 1/10W		R566,567			RK73GB2A102J	CHIP R 1.0K J 1/10W	
R132			RK73GB2A222J	CHIP R 2.2K J 1/10W		R581			RK73GB2A102J	CHIP R 1.0K J 1/10W	
R133			RK73GB2A123J	CHIP R 12K J 1/10W		W156,157			R92-2053-05	CHIP R 0 J 1/8W	
R136			RK73GB2A473J	CHIP R 47K J 1/10W		W158			R92-1252-05	CHIP R 0 OHM J 1/16W	
R138,139			RK73GB2A473J	CHIP R 47K J 1/10W		W161,162			R92-2053-05	CHIP R 0 J 1/8W	
R141			RD14BB2C472J	RD 4.7K J 1/6W		W165			R92-2053-05	CHIP R 0 J 1/8W	
R143			RD14BB2C472J	RD 4.7K J 1/6W		W405,406			R92-1252-05	CHIP R 0 OHM J 1/16W	K
R144			RK73GB2A104J	CHIP R 100K J 1/10W		W409			R92-1252-05	CHIP R 0 OHM J 1/16W	K
R145			RD14BB2C222J	RD 2.2K J 1/6W		W415			R92-2053-05	CHIP R 0 J 1/8W	
R163			RD14BB2C100J	RD 10 J 1/6W		W500,501			R92-1252-05	CHIP R 0 OHM J 1/16W	
R164,165			RD14BB2C471J	RD 470 J 1/6W		W504,505			R92-1252-05	CHIP R 0 OHM J 1/16W	
R166			RD14BB2C102J	RD 1.0K J 1/6W		W506			R92-2053-05	CHIP R 0 J 1/8W	
R167			RD14BB2C101J	RD 100 J 1/6W		W507			R92-1252-05	CHIP R 0 OHM J 1/16W	
R169			RD14BB2C102J	RD 1.0K J 1/6W		W508			R92-2053-05	CHIP R 0 J 1/8W	
R172			RD14BB2C102J	RD 1.0K J 1/6W		W509			R92-1252-05	CHIP R 0 OHM J 1/16W	
R174			RK73GB2A473J	CHIP R 47K J 1/10W		W510			R92-2053-05	CHIP R 0 J 1/8W	
R201			RK73GB2A473J	CHIP R 47K J 1/10W		W511			R92-1252-05	CHIP R 0 OHM J 1/16W	
R223,224			RK73FB2B271J	CHIP R 270 J 1/8W		W516			R92-1252-05	CHIP R 0 OHM J 1/16W	
R227,228			RD14BB2C303J	RD 30K J 1/6W		W517			R92-2053-05	CHIP R 0 J 1/8W	
R231,232			RD14BB2C101J	RD 100 J 1/6W		W519			R92-2053-05	CHIP R 0 J 1/8W	
R251			RK73GB2A472J	CHIP R 4.7K J 1/10W	K1	W521			R92-1252-05	CHIP R 0 OHM J 1/16W	
R252,253			RD14BB2C472J	RD 4.7K J 1/6W	K1	W523,524			R92-1252-05	CHIP R 0 OHM J 1/16W	
R254			RK73GB2A472J	CHIP R 4.7K J 1/10W	K1	W530			R92-2053-05	CHIP R 0 J 1/8W	
R255			RK73GB2A333J	CHIP R 33K J 1/10W		W531,532			R92-1252-05	CHIP R 0 OHM J 1/16W	
R256			RK73FB2B102J	CHIP R 1.0K J 1/8W	K1	W533			R92-2053-05	CHIP R 0 J 1/8W	
R257			RK73GB2A622J	CHIP R 6.2K J 1/10W		W534			R92-1252-05	CHIP R 0 OHM J 1/16W	
R258			RK73GB2A101J	CHIP R 100 J 1/10W	K1	W601			R92-1252-05	CHIP R 0 OHM J 1/16W	
R258			RK73GB2A221J	CHIP R 220 J 1/10W	K	D1			1N5393G-M6	DIODE	
R259			RD14BB2C223J	RD 22K J 1/6W		D3			IMSA-6801	SURGE ABSORBER	
R260			RK73GB2A751J	CHIP R 750 J 1/10W	K1	D10			MA4068(N)-M	ZENER DIODE	
R261			RK73GB2A100J	CHIP R 10 J 1/10W	K	D13			D1F60	DIODE	
R261			RK73GB2A431J	CHIP R 430 J 1/10W	K1	D14			AM01Z	DIODE	
R263			RK73GB2A184J	CHIP R 180K J 1/10W	K1	D20			MA4068(N)-M	ZENER DIODE	
R263			RK73GB2A432J	CHIP R 4.3K J 1/10W	K	D40			1SS133	DIODE	
R264			RK73GB2A473J	CHIP R 47K J 1/10W		D50			DAN202U	DIODE	
R415			RK73GB2A104J	CHIP R 100K J 1/10W		D51			MA4082(N)-L	ZENER DIODE	
R501			RK73GB2A682J	CHIP R 6.8K J 1/10W		D70			MA4068(N)-M	ZENER DIODE	
R502			RK73GB2A222J	CHIP R 2.2K J 1/10W		D101			1SS133	DIODE	
R503			RK73EB2E222J	CHIP R 2.2K J 1/4W		D103			DA204U	DIODE	
R505			RK73GB2A102J	CHIP R 1.0K J 1/10W		D201,202			MA4068(N)-M	ZENER DIODE	
R506			RK73GB2A105J	CHIP R 1.0M J 1/10W		D251-253			1SS133	DIODE	
R507			RK73GB2A102J	CHIP R 1.0K J 1/10W		D261-263			AM01Z	DIODE	K
R521-524			RK73GB2A104J	CHIP R 100K J 1/10W		D264			D1F60	DIODE	K
R525			RK73GB2A821J	CHIP R 820 J 1/10W		D264			S1J	DIODE	K
R526			RK73GB2A562J	CHIP R 5.6K J 1/10W		D265,266			AM01Z	DIODE	K
R527			RK73GB2A104J	CHIP R 100K J 1/10W							

K : KDC-1022 K1 : KDC-122P

△ Indicates safety critical components.

PARTS LIST

* New parts

Parts without **Parts No.** are not supplied.

Les articles non mentionnés dans le **Parts No.** ne sont pas fournis.

Teile ohne **Parts No.** werden nicht geliefert.

ELECTRIC UNIT (X25-9600-1x)

Ref. No.	A d d	N e w	Parts No.	Description	Desti- nation
D267,268			D1F60	DIODE	K
D267,268			S1J	DIODE	K
D501			RN739F	DIODE	
D503			RN739F	DIODE	
D504-506			KV1720S	VARIABLE CAPACITANCE DIODE	
IC1			UPD780058GC501	MICROCONTROLLER IC	
IC4			TDA7386	ANALOGUE IC	K1
IC4			TDA7560	ANALOGUE IC	K
IC7			BA4911-V4	ANALOGUE IC	
IC8			HD74HC27FP	MOS-IC	
IC10			TDA7513	ANALOGUE IC	
IC11			PST3435UL	MOS-IC	
IC12			BR24C01AF-W	ROM IC	
IC12			M24C01-WMN6T	ROM IC	
IC12			S-24CS02AFJ-TB	MEMORY IC	
Q10			2SC4081	TRANSISTOR	
Q20			2SC4081	TRANSISTOR	
Q40			DTA124EUA	DIGITAL TRANSISTOR	
Q50			2SA1036K	TRANSISTOR	
Q51			UMC2N	DIGITAL TRANSISTOR	
Q55			2SD2375	TRANSISTOR	
Q70			2SC4081	TRANSISTOR	
Q223,224			DTC143TUA	DIGITAL TRANSISTOR	
Q251			DTC114YUA	DIGITAL TRANSISTOR	K1
Q501			CPH5905	TRANSISTOR	
Q502			3SK126	DUAL FET	
TH1			PTH9C42BE471Q	POSITIVE RESISTOR	
CD PLAYER UNIT (X32-5380-00)					
C1			C92-0566-05	CHIP-TAN 10UF 6.3WV	
C2			CK73FB1A225K	CHIP C 2.2UF K	
C3			CK73GB0J105K	CHIP C 1.0UF K	
C5			CC73GCH1H020C	CHIP C 2.0PF C	
C6			CC73GCH1H390J	CHIP C 39PF J	
C7			CK73GB1C104K	CHIP C 0.10UF K	
C8			CK73GB0J105K	CHIP C 1.0UF K	
C9			CK73GB1H472K	CHIP C 4700PF K	
C10			CK73GB1C333K	CHIP C 0.033UF K	
C11			CK73GB1H682K	CHIP C 6800PF K	
C12			CK73GB1H332K	CHIP C 3300PF K	
C13			CC73GCH1H271J	CHIP C 270PF J	
C14			CK73GB1H472K	CHIP C 4700PF K	
C15			CK73GB1H222K	CHIP C 2200PF K	
C16			CC73GCH1H331J	CHIP C 330PF J	
C17,18			CK73GB1C104K	CHIP C 0.10UF K	
C31-34			CK73GB1C104K	CHIP C 0.10UF K	
C36			CK73FB1A225K	CHIP C 2.2UF K	
C37-39			CK73GB1H103K	CHIP C 0.010UF K	
C40			CK73GB1H153K	CHIP C 0.015UF K	
C41			CK73GB1H102K	CHIP C 1000PF K	
C42			CK73GB1E473K	CHIP C 0.047UF K	
C43			CK73GB1H222K	CHIP C 2200PF K	
C44			CK73GB1H102K	CHIP C 1000PF K	
C45-47			CK73GB1C104K	CHIP C 0.10UF K	
C48			CK73GB1H682K	CHIP C 6800PF K	

Ref. No.	A d d	N e w	Parts No.	Description	Desti- nation
C49			CK73GB1H152K	CHIP C 1500PF K	
C50			CK73GB1H472K	CHIP C 4700PF K	
C51			CK73GB1H681K	CHIP C 680PF K	
C52			CK73GB1C104K	CHIP C 0.10UF K	
C61			CK73FB1A225K	CHIP C 2.2UF K	
C69-72			CK73GB1H222K	CHIP C 2200PF K	
C75,76			CK73GB1H682K	CHIP C 6800PF K	
C100-102			CK73GB1H102K	CHIP C 1000PF K	
CN1			E40-9536-05	FLAT CABLE CONNECTOR (16P)	
CN1			E41-0193-05	FLAT CABLE CONNECTOR (16P)	
CN2			E40-9339-05	FLAT CABLE CONNECTOR (22P)	
CN2			E41-0129-05	FLAT CABLE CONNECTOR	
X1			L78-0851-05	RESONATOR 16.93MHZ	
CP1			R90-1019-05	MULTI-COMP 100 X2	
CP2			R90-1014-05	MULTI-COMP 100 X4	
CP3			R90-0974-05	MULT R 1.8K X4	
CP4			R90-0718-05	MULTI-COMP 4.7K X4	
CP5			R90-0720-05	MULTI-COMP 100K X4	
R1			RK73GB2A910J	CHIP R 91 J 1/10W	
R2,3			RK73GB2A562J	CHIP R 5.6K J 1/10W	
R4			RK73FB2B100J	CHIP R 10 J 1/8W	
R5,6			RK73GB2A332J	CHIP R 3.3K J 1/10W	
R7			RK73GB2A362J	CHIP R 3.6K J 1/10W	
R8			RK73GB2A273J	CHIP R 27K J 1/10W	
R9			RK73GB2A392J	CHIP R 3.9K J 1/10W	
R10			RK73GB2A104J	CHIP R 100K J 1/10W	
R11			RK73GB2A333J	CHIP R 33K J 1/10W	
R12			RK73GB2A244J	CHIP R 240K J 1/10W	
R13			RK73GB2A914J	CHIP R 910K J 1/10W	
R14			RK73GB2A104J	CHIP R 100K J 1/10W	
R15			RK73GB2A472J	CHIP R 4.7K J 1/10W	
R31			RK73GB2A273J	CHIP R 27K J 1/10W	
R32			RK73GB2A103J	CHIP R 10K J 1/10W	
R33			RK73GB2A183J	CHIP R 18K J 1/10W	
R34			RK73GB2A103J	CHIP R 10K J 1/10W	
R35			RK73GB2A393J	CHIP R 39K J 1/10W	
R36			RK73GB2A103J	CHIP R 10K J 1/10W	
R37			RK73GB2A622J	CHIP R 6.2K J 1/10W	
R38			RK73GB2A224J	CHIP R 220K J 1/10W	
R39			RK73GB2A104J	CHIP R 100K J 1/10W	
R40			RK73GB2A821J	CHIP R 820 J 1/10W	
R41			RK73GB2A473J	CHIP R 47K J 1/10W	
R42			RK73GB2A472J	CHIP R 4.7K J 1/10W	
R43			RK73GB2A102J	CHIP R 1.0K J 1/10W	
R44,45			RK73GB2A103J	CHIP R 10K J 1/10W	
R46			RK73GB2A273J	CHIP R 27K J 1/10W	
R47			RK73GB2A222J	CHIP R 2.2K J 1/10W	
R48			RK73GB2A103J	CHIP R 10K J 1/10W	
R49			RK73GB2A473J	CHIP R 47K J 1/10W	
R50			RK73GB2A392J	CHIP R 3.9K J 1/10W	
R51			RK73GB2A103J	CHIP R 10K J 1/10W	
R52,53			RK73GB2A472J	CHIP R 4.7K J 1/10W	
R71			RK73GB2A133J	CHIP R 13K J 1/10W	

K : KDC-1022 K1 : KDC-122P

△ Indicates safety critical components.

PARTS LIST

* New parts

Parts without **Parts No.** are not supplied.

Les articles non mentionnés dans le **Parts No.** ne sont pas fournis.

Teile ohne **Parts No.** werden nicht geliefert.

CD PLAYER UNIT (X32-5380-00)

Ref. No.	A d d	N e w	Parts No.	Description	Desti- nation
R72			RK73FB2B201J	CHIP R 200 J 1/8W	
R81,82			RK73FB2B331J	CHIP R 330 J 1/8W	
R85,86			RK73FB2B331J	CHIP R 330 J 1/8W	
R87,88			RK73FB2B101J	CHIP R 100 J 1/8W	
R93			RK73GB2A104J	CHIP R 100K J 1/10W	
R100			RK73GB2A100J	CHIP R 10 J 1/10W	
S1,2			S68-0863-05	PUSH SWITCH	
S3			S68-0862-05	PUSH SWITCH	
D1			DAN202U	DIODE	
D1			MA142WK	DIODE	
D2			MA8051-L	ZENER DIODE	
D3			DA204U	DIODE	
IC1			AN22002AA	ANALOGUE IC	
IC2			MN6627771KP	MOS-IC	
IC3			BA5824FP	ANALOGUE IC	
Q1			MCH6101	TRANSISTOR	
Q2			2SA1362(Y)	TRANSISTOR	
Q3			DTC124EUA	DIGITAL TRANSISTOR	
Q3			UN5212	TRANSISTOR	
Q4			DTA143XUA	DIGITAL TRANSISTOR	
Q5			2SC4081	TRANSISTOR	
Q6			2SA1576A	TRANSISTOR	
CD MECHANISM ASSY (X92-4640-00)					
2	1B		A10-4827-12	CHASSIS	
5	1B		D10-4576-53	ARM ASSY	
8	2A		D10-4579-13	LEVER ASSY	
10	2A		D10-4581-13	ARM	
11	2A		D10-4582-13	ARM	
12	3A		D10-4583-03	ARM	
13	3A		D10-4584-03	ARM	
14	3B		D10-4585-03	ARM	
15	2A		D10-4586-13	SLIDER	
16	3B		D10-4587-32	SLIDER	
17	2B		D10-4588-13	SLIDER	
18	2B		D10-4595-04	ARM	
19	3B		D10-4596-14	ARM	
22	2A		D13-2151-04	GEAR	
23	2B		D13-2152-04	GEAR	
24	3B		D13-2153-04	GEAR	
25	3B		D13-2154-04	GEAR	
26	3B		D13-2155-04	WORM	
27	2B		D13-2156-14	GEAR	
28	3B		D13-2157-04	GEAR	
29	3B		D13-2158-04	GEAR	
30	2B		D13-2168-04	GEAR	
31	3B		D13-2171-04	GEAR	
32	2B		D13-2172-03	RACK (GEAR)	
33	2A		D14-0759-04	ROLLER	
35	2B		D21-2382-04	SHAFT	
36	1A		D23-0954-04	RETAINER	
37	1B		D39-0246-05	DAMPER	
38	2B		G01-3072-04	EXTENSION SPRING	

Ref. No.	A d d	N e w	Parts No.	Description	Desti- nation
39	2A		G01-3073-04	TORSION COIL SPRING	
40	2A		G01-3074-04	EXTENSION SPRING	
41	1B		G01-3075-04	EXTENSION SPRING	
42	2A		G01-3076-04	EXTENSION SPRING	
43	1B		G01-3077-04	EXTENSION SPRING	
44	2B		G02-1399-04	FLAT SPRING	
45	2B		G02-1408-04	FLAT SPRING	
51	1A		J21-9676-22	MOUNTING HARDWARE	
52	3B	*	J21-9677-12	MOUNTING HARDWARE	
53	1B	*	J21-9678-13	MOUNTING HARDWARE	
55	1A		J90-1001-11	GUIDE	
56	1B		J90-1023-03	GUIDE	
A	2B		N09-4460-05	TAPTITE SCREW (OVAL P TAPTIT)	
B	1B		N09-4472-05	MACHINE SCREW (M1.7X8.5)	
C	2B		N09-6004-05	MACHINE SCREW (M1.7X2.5 IB-L)	
E	2B		N09-6007-05	MACHINE SCREW (PAN M2X2)	
F	1A		N09-6051-05	TAPTITE SCREW (BIND P 2X5)	
G	2A		N19-2163-04	FLAT WASHER	
H	1B		N39-2020-46	PAN HEAD MACHIN SCREW	
J	1B		N09-6108-05	MACHINE SCREW (M2*3.5TYPE3)	
K	3B	*	N09-6155-05	SEMS (TAPTITE SCREW) (PT2X6)	
DM1	3B		T42-1066-04	DC MOTOR ASSY (SP)	
DM2	2B		T42-1067-04	DC MOTOR ASSY (LO)	
DPU1	2B		X93-2010-00	OPTICAL PICKUP ASSY	

K : KDC-1022 K1 : KDC-122P

△ Indicates safety critical components.

KDC-1022/122P

SPECIFICATIONS

FM

Frequency Range (Frequency step)
..... 87.9MHz~107.9MHz (200kHz)
Channel Space Selection 50k/200kHz
Usable Sensitivity (S/N 30dB) 9.3dBf (0.8 μ V/75 Ω)
Quieting Sensitivity (S/N 50dB) 15.2dBf (1.6 μ V/75 Ω)
Frequency Response (\pm 3.0dB) 30Hz~15kHz
S/N 70dB (MONO)
Selectivity \geq 80dB (\pm 400kHz)
Stereo Separation 40dB (1kHz)

AM

Frequency Range (Frequency step)
..... 530kHz~1700kHz (10kHz)
Channel Space Selection 9k/10kHz
Usable Sensitivity (S/N 20dB) 28dB μ (25 μ V)

CD

Laser Diode GaAlAs (λ =780nm)
Digital Filter (D/A) 8 Times Over Sampling
D/A Converter 1 Bit
Spindle Speed (CD-DA) 500~200rpm (CLV)
Wow & Flutter Below Measurable Limit
Frequency Response 10Hz~20kHz
Total Harmonic Distortion 0.01% (1kHz)
S/N Ratio 96dB (1kHz)
Dynamic Range 93dB
Channel Separation 85dB

Preout Level/Load (Unbalanced) 2000mV/10k Ω (CD)

Preout Impedance \leq 600 Ω

Amplifier

Maximum Power KDC-1022 : 50W x 4

KDC-122P : 45W x 4

Full Bandwidth Power (at less than 1% THD) 22W x 4

Tone

Bass 100Hz \pm 10dB

Middle 1kHz \pm 10dB

Treble 10kHz \pm 10dB

General

Operating Voltage (11V~16V allowable) 14.4V

Current Consumption 10A

Installation Size (WxHxD) 182 x 53 x 157 (mm)

7-3/16 x 2-1/16 x 6-3/16 (in)

Weight 3.1 lbs (1.4kg)

KENWOOD follows a policy of continuous advancements in development. For this reason specifications may be changed without notice.

KENWOOD CORPORATION

2967-3, Ishikawa-machi, Hachioji-shi, Tokyo, 192-8525 Japan

KENWOOD USA CORPORATION
P.O. BOX 22745, 2201 East Dominguez Street, Long Beach, CA 90801-5745, U.S.A.

KENWOOD ELECTRONICS CANADA INC.
6070 Kestrel Road, Mississauga, Ontario, Canada L5T 1S8

KENWOOD ELECTRONICS LATIN AMERICA S.A.
P.O. Box 55-2791 Paitilla, Plaza Credicorp Bank Panama,
Piso 9, Oficina 901, Calle 50, Panama, Rep. de Panama

KENWOOD ELECTRONICS BRASIL LTDA.
Alameda Ministro Rocha Azevedo No. 456,
Edifício Jaú, 10o Andar, Cerqueira César, Cep 0140-001,
São Paulo-SP-Brasil

KENWOOD ELECTRONICS UK LIMITED
Kenwood House, Dwight Road, Watford, Herts, WD18 9EB, United Kingdom

KENWOOD ELECTRONICS DEUTSCHLAND GMBH
Rembrücker-Str. 15, 63150 Heusenstamm, Germany

KENWOOD ELECTRONICS FRANCE S.A.
13, Boulevard Ney, 75018 Paris, France

KENWOOD ELECTRONICS BELGIUM N.V.
Leuvensesteenweg 248 J, 1800 Vilvoorde, Belgium

KENWOOD ELECTRONICS ITALIA S.p.A.
Via G. Sirtori 7/9, 20129 Milano, Italy

KENWOOD IBÉRICA S.A.
Bolivia, 239-08020 Barcelona, Spain

KENWOOD ELECTRONICS AUSTRALIA PTY. LTD. (A.C.N. 001 499 074)
16 Giffnock Avenue, Centrecourt Estate, North Ryde,
N.S.W. 2113, Australia

KENWOOD ELECTRONICS (HONG KONG) LTD.
Unit 3712-3724, Level 37, Tower 1, Metroplaza, 223 Hing Fong Road, Kwai Fong, N.T.,
Hong Kong

KENWOOD ELECTRONICS GULF FZE
P.O. Box 61318, Jebel Ali, Dubai, U.A.E.

KENWOOD ELECTRONICS (THAILAND) CO., LTD.
2019 New Pechburi Road, Bangkok, Huaykwang, Bangkok, 10320 Thailand

KENWOOD ELECTRONICS SINGAPORE PTE. LTD.
1 Genting Lane, #07-00, Kenwood Building, Singapore, 349544

KENWOOD ELECTRONICS (MALAYSIA) SDN BHD
#4.01 Level 4, Wisma Academy Lot 4A, Jalan 19/1, 46300 Petaling Jaya, Selangor Darul Ehsan,
Malaysia